

Contents

| | |
|--|-------------|
| Types of Power Distribution Systems | T-2 – T-4 |
| Ground Fault Protection | T-5 – T-10 |
| Overcurrent Protection and Coordination | T-11 |
| System Analysis | T-12 |
| Current Limiting Circuit Breaker Technology | T-13 |
| Series-Connected Combination Ratings | T-14 |
| Harmonics / K-factor Ratings | T-15 – T-16 |
| Table 1: Ampacities of Insulated Conductors | T-17 |
| Table 2: Correction Factors for Ambient Temperatures | T-17 |
| Table 4A: Motor Full-Load Currents of Three Phase AC Induction Type Motors | T-18 |
| Table 4B: Motor Full-Load Currents in Amperes, Single Phase AC | T-18 |
| Table 4C: Motor Full-Load Currents in Amperes, DC | T-18 |
| Table 4D: Conversion Table of Polyphase Design | T-18 |
| Table 5: Normal-Load and Fault Currents of Three Phase Transformers | T-18 |
| Table 6: Electrical Formulas for Finding Amperes, Horsepower Kilowatts, and kVA | T-19 |
| Table 7: Grounding Electrode Conductor for AC Systems | T-19 |
| Table 8: Minimum Size Grounding Conductors for Grounding Raceways and Equipment | T-19 |
| Capacitor Circuit Conductors | T-20 |
| Conversion Table | T-21 |

Scan to connect
online to the
most up-to-
date version of
this Section of
SPEEDFAX.



There are several basic considerations which must be included by the system design engineer to select and design the best power distribution system which will supply power to both present and future loads most economically. Among these are:

- Safety
- Reliability
- Maintenance
- Flexibility
- Voltage Regulation
- Initial Investment
- Simplicity of Operation

The characteristics of electrical service available at the building site, the types of loads, the quality of service required, and the size and configuration of building are also important factors that will influence system design and circuit arrangement.

Four basic circuit arrangements are used for the distribution of electric power. They are the radial, primary selective, secondary selective, and secondary network circuit arrangements. The following discussion of these circuit arrangements covers both the high-voltage and low-voltage circuits. The reader should recognize that the high-voltage circuits and substations may be owned by either the utility company or the building owner, depending upon the electric rates, the practice, and requirements of the particular electric utility serving the specific building site.

Radial System

If power is brought into a building at utilization voltage, the simplest and the lowest cost means of distributing the power is to use a radial circuit arrangement. The radial system is the simplest that can be used, and has the lowest system investment. It is suitable for smaller installations where continuity of service is not critical.

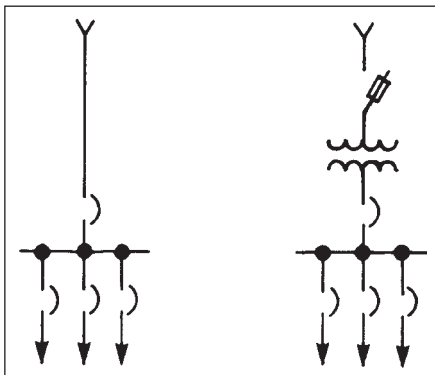

Figure 1. Radial Systems

The low voltage service entrance circuit comes into the building through service entrance equipment and terminates at a main switchgear assembly, switchboard or panelboard. Feeder circuits are provided to the loads or to other subswitchboards, distribution cabinets, or panelboards.

Figure 1 shows the two forms of radial circuit arrangements most frequently used. Under normal operating conditions, the entire load is served through the single incoming supply circuit, and in the case of high voltage service, through the transformer. A fault in the supply circuit, the transformer, or the main bus will cause an interruption of service to all loads. A fault on one of the feeder or branch circuits should be isolated from the rest of the system by the circuit protective device on that circuit. Under this condition, continuity of service is maintained for all loads except those served from the faulted circuit.

The need for continuity of service often requires multiple paths of power supply as opposed to the single path of power supply in the radial system.

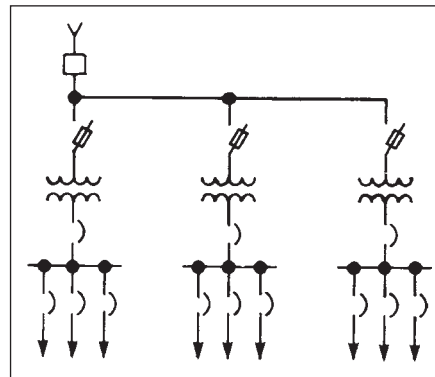

Figure 2. Expanded Radial System—Single Primary Feeder

A fault in a primary feeder in the arrangement shown in Figure 2 will cause the main protective device to operate and interrupt service to all loads. If the fault were in a transformer, service could be restored to all loads except those served from that transformer. If the fault were in a primary feeder, service could not be restored to any loads until the source of trouble had been eliminated. Since it is to be expected that more faults will occur on the feeders than in the transformers, it becomes logical to consider providing individual circuit protection on the primary feeders as shown in Figure 3. This arrangement has the advantage of

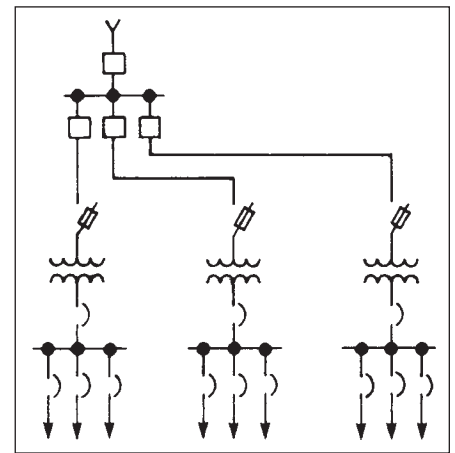

Figure 3. Expanded Radial Systems individual Primary Feeder Protection

making it possible to limit outages due to a feeder or transformer fault to the loads associated with the faulted equipment. If circuit breakers are used for primary feeder protection, the cost of this system will be high. Even if fused switches are used, the cost of the arrangement of Figure 3 will exceed the cost of the arrangement of Figure 2.

Primary Selective System

The circuit arrangement of Figure 4 provides means of reducing both the extent and duration of an outage caused by a primary feeder fault. This operating feature is provided through the use of duplicate primary feeder circuits and load interrupter switches that permit connection of each secondary substation transformer to either of the two primary feeder circuits. Each primary feeder circuit must have sufficient capacity to carry the total load in the building.

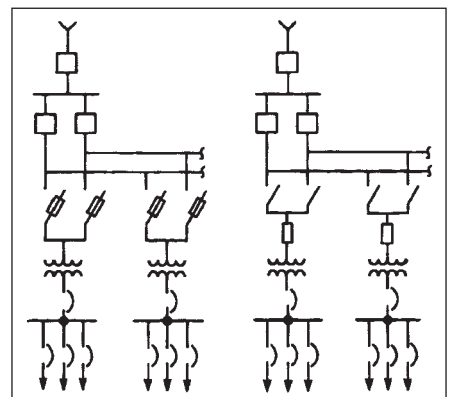

Figure 4. Primary Selective Systems

Under normal operating conditions, the appropriate switches are closed in an attempt to divide the load equally between the two primary feeder circuits. Then, should a primary feeder fault occur, there is an interruption of service to only half of the load. Service can be restored to all loads by switching the deenergized transformers to the other primary feeder circuit. The primary selective switches are usually manually operated and outage time for half the load is determined by the time it takes to accomplish the necessary switching. An automatic throwover switching arrangement could be used to avoid the interruption of service to half the load. However, the additional cost of the automatic feature may not be justified in many applications. If a fault occurs in a secondary substation transformer, service can be restored to all loads except those served from the faulted transformer.

The higher degree of service continuity afforded by the primary selective arrangement is realized at a cost somewhat higher than a simple radial system due to the extra primary cables and switchgear.

Secondary Selective System

Under normal conditions, the secondary selective arrangement of Figure 5 is operated as two separate radial systems. The secondary tie circuit breaker in each secondary substation is normally open.

The load served from a secondary selective substation should be divided equally between the two bus sections. If a fault occurs on a primary feeder or in a transformer, service is interrupted to all loads associated with the faulted feeder or transformer. Service may be restored to all secondary buses by first opening the main secondary switch or circuit breaker associated with the faulted transformer and primary feeder, and then closing the tie breaker. The two transformer secondary circuit breakers in each substation should be interlocked with the secondary tie breaker in such a manner that all three cannot be in the closed position simultaneously. This prevents parallel operation of the two transformers and thereby minimizes the interrupting duty imposed on the secondary switching devices. It also eliminates the possibility of interrupting service to all loads on the bus when a fault occurs in either a primary feeder or a transformer.

The cost of the secondary selective system will depend upon the spare capacity in the transformers and primary feeders. The minimum transformer and primary feeder capacity will be determined

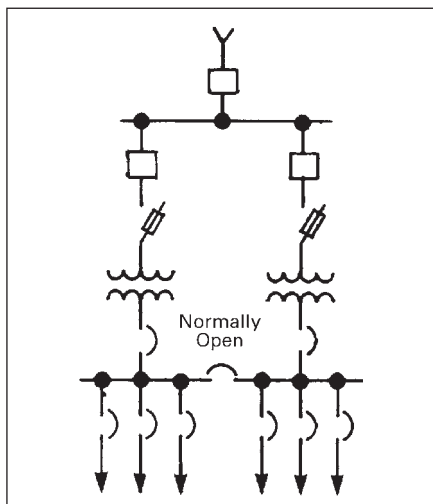

Figure 5. Secondary Selective System Using Close-Coupled Double-Ended Substation

by essential loads that must be served under emergency operating conditions. If service is to be provided for all loads under emergency conditions, then each primary feeder should have sufficient capacity to carry the total load, and each transformer should be capable of carrying the total load in each substation.

This type of system will be more expensive than either the radial or primary selective system, but it makes restoration of service to all essential loads possible in the event of either a primary feeder or transformer fault. The higher cost results from the duplication of transformer capacity in each secondary substation. This cost may be reduced by shedding nonessential loads.

A modification of the secondary selective circuit arrangement is shown in Figure 6. In this arrangement there is only one transformer in each secondary substation, but adjacent substations are interconnected in pairs by a normally open low voltage tie circuit. When the primary feeder or transformer supplying one secondary substation bus is out of service, the essential loads on that substation bus can be supplied over the tie circuit. The operating aspects of this system are somewhat complicated if the two substations are separated by distance. The best arrangement is to use close-coupled, double-ended substations.

Secondary Network System

Many buildings with radial distribution systems are served at utilization voltage from utility secondary network systems. The network supply system assures a relatively high degree of service reliability. The utility network may take the form of a

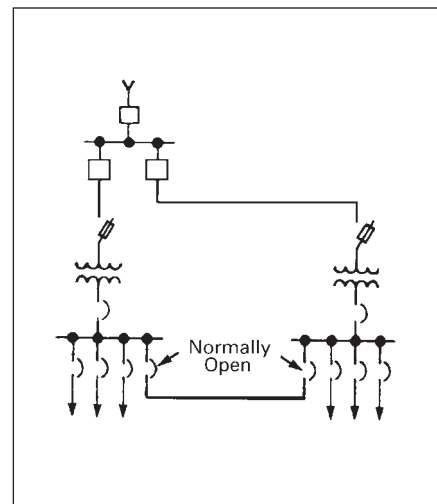

Figure 6. Secondary Selective System Using Two Single-Ended Substations With Cable or Bus Tie

distributed network or a spot network. If the building demand is in the order of 750 kVA or higher, a spot network will often be established to serve the building. In buildings where a high degree of service reliability is required, and where spot network supply may not be available, the distributed secondary network system is often used. This is particularly true of institutional buildings such as hospitals. The network may take the form of several secondary substations interconnected by low voltage circuits. However, the most common practice is to use some form of the spot network circuit arrangement.

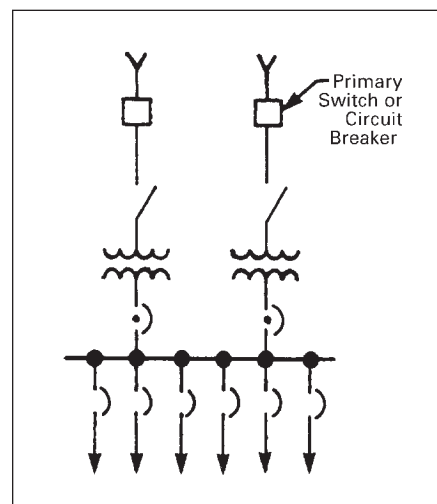

Figure 7. Simple Spot Network System

A simple spot network, such as shown in Figure 7, consists of two or more identical transformers supplied over separate primary feeder circuits. The transformers are connected to a common low voltage

bus through network protectors and are operated in parallel. A network protector is an electrically operated power circuit breaker controlled by network relays in such a way that the circuit breaker automatically opens when power flows from the low voltage bus toward the transformer. When voltages in the system are such that power would flow toward the low voltage bus from the transformer, it will close automatically.

Network protectors are normally equipped with relays which operate for faults in the network transformer or high voltage feeder only. The network is often operated on the assumption that network failure will “burn” open.

Network protectors without supplementary protection do not meet the requirements of the NEC for overcurrent, ground fault, or short circuit protection. Protection of the network or collector bus may be added by providing sensing devices, including ground fault detection, with tripping of the network protectors. The most common use of the network protector, however, has been by utilities in vaults where failure of the network devices could cause damage limited to the vault. High integrity design involving wide phase separation and the use of “catastrophe” fusing minimize the danger and extent of a network failure. A conventional circuit breaker with time overcurrent and instantaneous trip devices plus network relays can meet the NEC requirements. However, the full reliability of the network may be compromised since selectivity between these devices is difficult to obtain.

Under normal operating conditions, the total load connected to the bus is shared equally by the transformers. Should a fault occur in a transformer or on a primary feeder, the network protector associated with the faulted transformer or feeder will open on reverse power flow to isolate the fault from the low voltage bus. The remaining transformer or transformers in the substation will continue to carry the load and there will be no interruption of service to the loads, except for a voltage dip during the time that it takes for the protective equipment to operate.

If only two transformers are used in a spot network substation, each transformer must be capable of carrying the total load served from the low voltage bus. The amount of spare transformer capacity in the substation can be reduced by using a primary

selective switching arrangement with each transformer, or by using three or more transformers. If the primary selective switching arrangement is used, the total load can be about 160 percent of the nameplate rating of one of the transformers. This produces an overload on one transformer until such time as the remaining transformer can be switched to the other feeder in the case of a primary feeder fault.

The interrupting duty imposed on the low voltage protective devices in a spot network substation is higher than in radial, primary selective, or secondary selective substations having the same load capability because of the spare transformer capacity required in the spot network substation and because the transformers are operated in parallel.

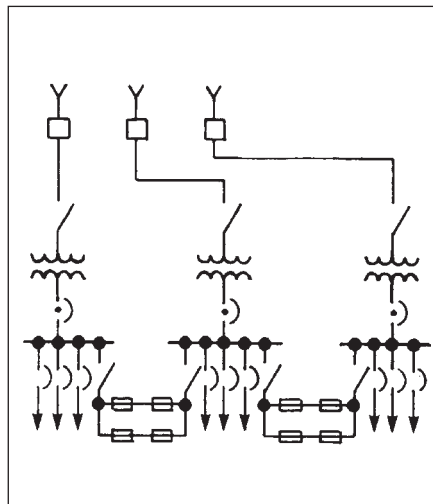

Figure 8. Secondary Network System

The spare transformer capacity, the network protectors, and the higher interrupting duty will make the secondary network arrangement much more expensive than the other arrangements. At the same time, these elements make the reliability of the network system greater than for the other system configurations.

The secondary network may also take the form shown in Figure 8. In this arrangement there is only one transformer in each secondary substation, and the substations are interconnected by normally closed low voltage tie circuits. The tie circuits permit interchange of power between substations to accommodate unequal loading on the substations and to provide multiple paths of power flow to the

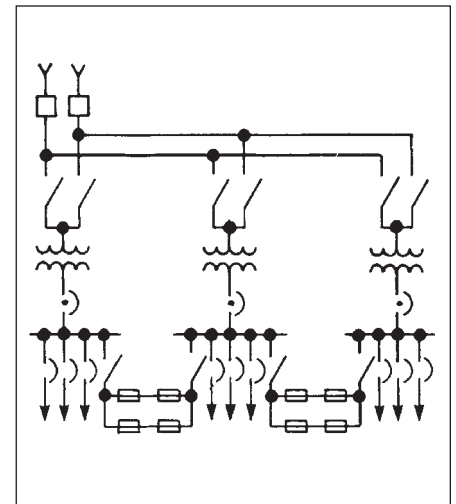

Figure 9. Primary Selective Secondary Network System

various load buses. In normal operation, the substations are about equally loaded and the current flowing in the tie circuits is relatively small. However, if a network protector opens to isolate a transformer on a primary feeder fault, the load on the associated bus is then carried by the adjacent network units and is supplied over the tie circuits. This arrangement provides for continuous power supply to all low voltage load buses, even though a primary feeder circuit or a transformer is taken out of service.

In the network arrangement in Figure 9, if there were three incoming primary feeder circuits and three transformers, the combined capacity of two of the transformers should be sufficient to carry the entire load on the three substations on the basis that only one feeder is out of service at one time. Generally, these transformers would all have the same ratings. With this arrangement, as with the spot network arrangement, a reduction in spare transformer capacity can be achieved, if a primary selective switching arrangement is used at each substation transformer. However, if three or more primary feeder circuits are available, the reduction in transformer capacity achieved through the use of a primary selective arrangement may be small.

Cable ties or busway ties, as shown in Figures 8 and 9, will require careful consideration during contingencies and of the safety aspects with regard to backfeeds. Key or other mechanical interlocking of switches or circuit breakers may be essential.

The term “low magnitude” arcing ground fault is a deceptive description of this type fault. What is meant by this is that the fault current magnitude is low compared to that of a bolted fault. Even so, the arc energy released at the point of the fault can cause much damage and may result in a fire. A ground fault is an insulation failure between an energized conductor and ground. A phase-to-ground arcing fault, unlike a phase-to-phase bolted fault, is a high-impedance type fault. The factors that contribute to this high impedance are the resistance of the arc and the impedance of the return path. This return path is usually metal conduit, raceway, busway housing or switchboard frames. Another contributing factor is the spasmodic nature of the arc. The circuit breaker or fuse protecting the circuit detects the fault current, but the actual ground fault current magnitude is ever changing due to arc elongating blowout effects, self-clearing attempts and arc reignition.

These current limiting effects make the circuit breaker or fuse incapable of detecting the actual damage that is occurring. This is not to imply that these devices are inadequate. The problem is one of system protection because the circuit breaker must be adjusted (or fuse size selected) so as to hold without tripping under momentary overload conditions, such as motor starting current or transformer inrush current. Therefore, the circuit breaker or fuse cannot open quickly enough under relatively low magnitude faults to limit the arcing damage.

Figure 10 illustrates the basic problem. Shown is a typical distribution system with a 1600 ampere main service entrance unit with a circuit breaker (single line “a”) or fused service protector (single line “b”). A ground fault of 1500 amperes on the bus would affect but would not open either device. A 4000 ampere ground fault would be cleared in approximately 35 seconds by the circuit breaker and in 230 seconds by the fuse. To allow a fault of this magnitude to persist for this length of time would create more than 92,000 kW seconds of arc energy. As a result of tests made, it has been determined that an arc with a value of 1050 kW seconds of energy would vaporize about 1.0 cubic in. of copper or 2.5 cubic in. of aluminum. Obviously a fault of the magnitude shown in Figure 10 could cause a considerable amount of damage.

The nature of low-level arcing ground faults makes impractical their detection

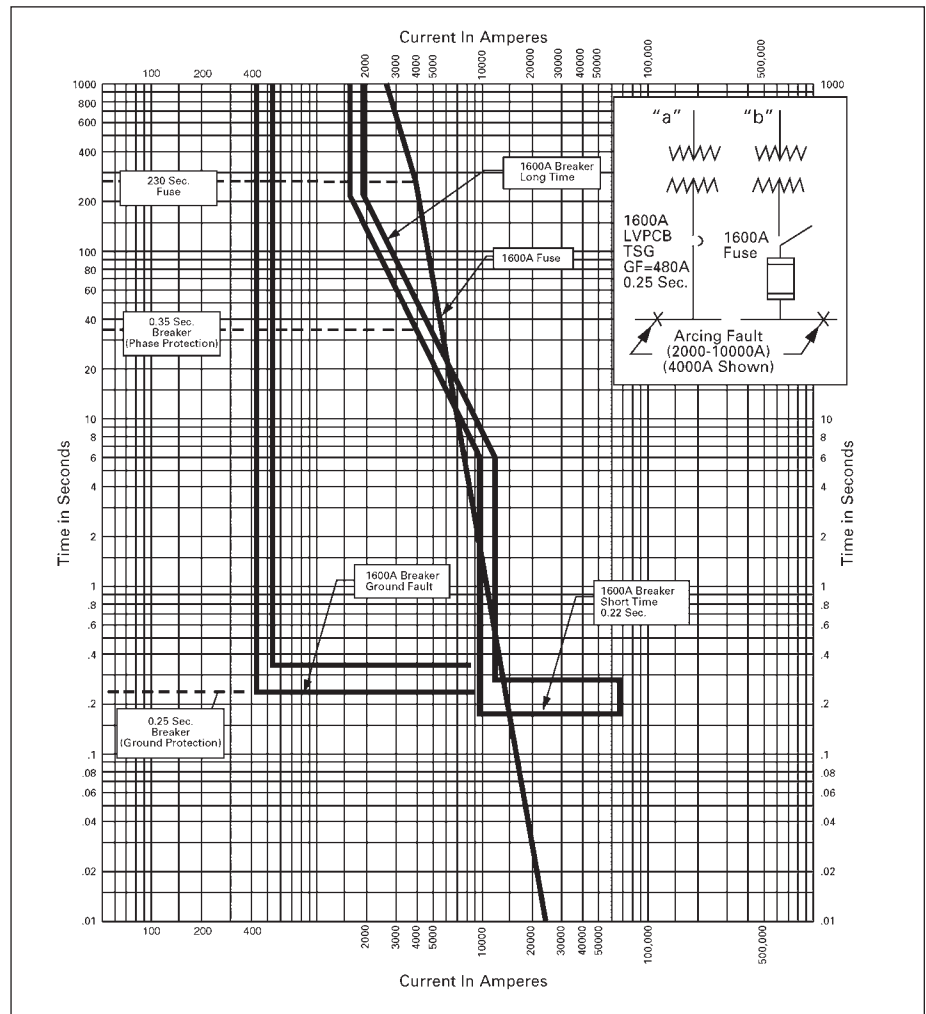

Figure 10. Ground Fault Protection

by a traditional overcurrent devices. To complete total protection of the system against all possible types of faults, other means are utilized to detect ground fault currents, including:

- **Zero sequence method**
- **Source ground current (or ground return) method**
- **Residual connection method**

Zero Sequence Method

This is commonly used when ground fault protection is provided for equipment employing electromechanical trip devices. The scheme uses a core balance type current transformer (ground sensor) which encircles all phase conductors (and neutral on four wire system) to detect ground faults.

The operation of this system is such that under normal operating conditions (eg., no ground fault on the system) there is

no output from the ground sensor to the tripping relay because the vector sum of all the currents through the sensor window is zero.

$$(I_a + I_b + I_c + I_n = 0)$$

If a ground fault occurs on the system, there is now an additional current (I_g) seen by ground sensor which returns to the source by a path other than through the sensor window. The sensor now sees an unbalance caused by I_g and operates the ground relay which trips the circuit protector.

$$(I_a + I_b + I_c + I_n = I_g)$$

The ground sensor is located downstream from the point at which the system is grounded and can be mounted either on the line side or load side of the main disconnect device. This method can be used on incoming main disconnect or on feeders.

Source Ground Current (or Ground Return) Method

This method of detecting the ground fault current I_g locates the ground sensor on the neutral connection to ground at the service entrance. This means that the ground sensor only detects ground fault current. This type of detection has some limitations because it is detecting the ground fault return current. On multiple source systems with multiple connections to ground, this ground fault current can return by more than one path, therefore, some sensitivity in detecting these faults would be lost.

Residual Connection Method

Current sensors, one on each of the phase conductors and on the neutral conductors, are connected in common. This common (or residual connection) measures the vector summation of the phase currents and the neutral current. Under normal conditions, this vector summation will be zero, and no current will be applied to the ground relay.

If a fault involving ground occurs, the current summation is not equal to zero. Current flows into common connection which is applied to the relay. This method of detecting ground fault current is used in circuit breakers with electronic trip device.

Residual Ground Current Sensing

3-Wire System

This system is used with electronic trip units, and always includes three current sensors mounted on the circuit breaker. A trip element is connected in series with each sensor to provide phase overcurrent protection. By adding a ground trip element in the residual (neutral) circuit of the three current sensors, it will sense ground fault current only, and not load current. This permits more sensitive settings to protect against low magnitude ground faults. This scheme is shown in Figure 14.

Under normal conditions, the vector sum of the current in all of the phases equals zero. No current would flow in the GND element, which is also true under the condition of a phase-to-phase fault.

A phase-to-ground fault would cause a current to flow in the GND trip element. If the magnitude of this current exceeds the pickup setting for the required time, the trip unit will operate to trip the breaker.

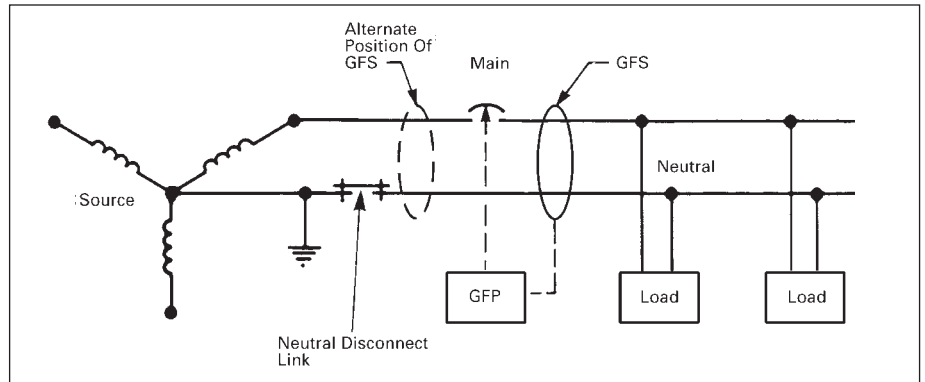

Figure 11. Schematic for Zero Sequence

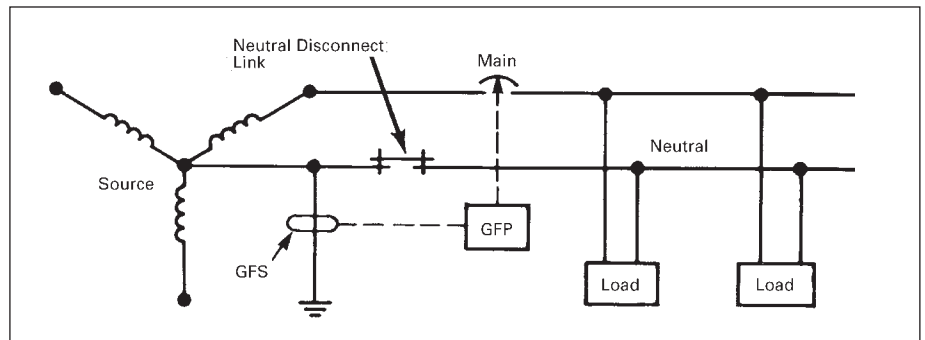

Figure 12. Schematic for Source Ground Current

GFS = Ground Fault Sensor
GFP = Ground Fault Protection (Relay or Trip Unit)

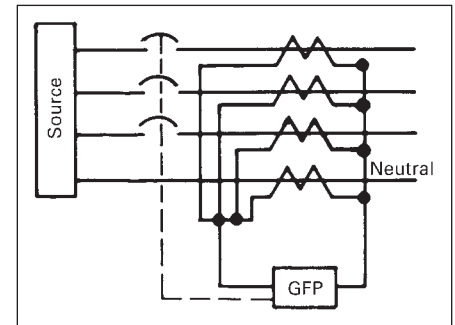

Figure 13. Schematic for Residual Method

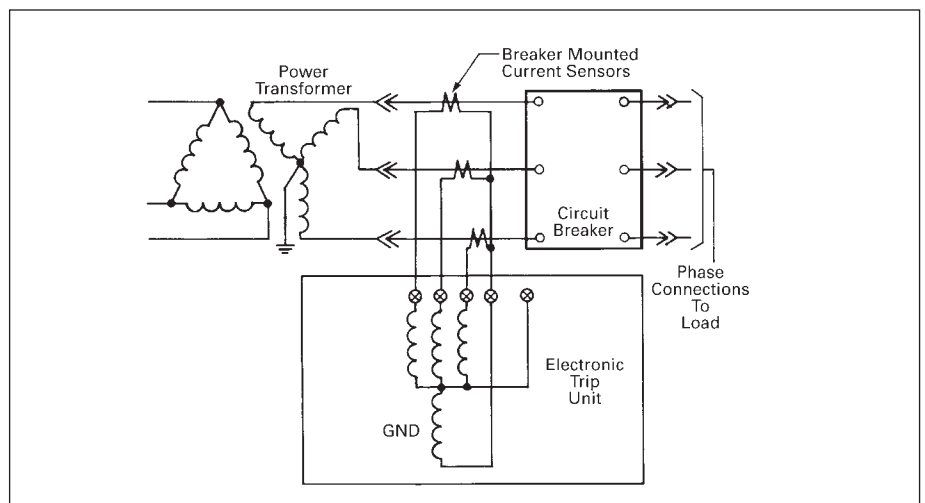

Figure 14. Schematic for Ground Protection on 3-Wire Systems, Residual Sensing

4-Wire System

To avoid false tripping, a fourth current sensor is connected in the neutral conductor to sense normal neutral current. This fourth sensor is connected so that it cancels the normal neutral current which is developed in the residual circuit as shown in Figure 15.

Under normal conditions, the vector sum of the current in all phases equals the neutral current. Disregarding the effects of the neutral sensor connection, the neutral current would flow through the GND element. Since this is normal neutral current, pickup of the GND element is not desired. Therefore, the neutral sensor is added to sense the same neutral current as the GND sensor — but opposite in polarity. The result is a circulating current between the phase sensing current sensors and the neutral sensor, with no current flowing through the GND sensor. This is similar to a differential relay circuit. When a phase-to-ground fault occurs, the vector sum of the phase currents will no longer equal the neutral current because the ground

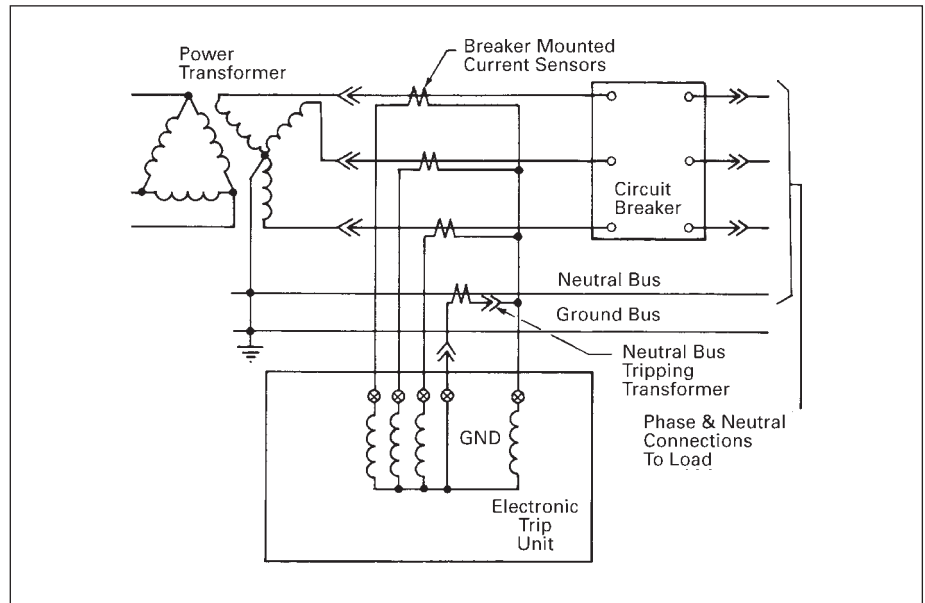

Figure 15. Schematic for Ground Protection on 4-Wire Systems, Residual Sensing

fault current returns via the ground bus and bypasses the neutral. If the magnitude of the phase-to-ground

current exceeds the pickup setting of the GND element for the required time, the trip unit will operate to open the breaker.

Types Of Coordinated Ground Fault Tripping Systems

There are two types of Coordinated Ground Fault Systems:

- **Time / Current Selective**
- **Zone Selective (Zone Interlock)**

Time / Current Selective

In this system the time / current characteristics of the Ground Fault Protection (GFP) devices used with each disconnect are coordinated so that the nearest disconnect supplying the ground fault location will open. Any upstream disconnects remain closed and continue to supply the remaining load current. Each set of GFP devices should have a specified time-current operating characteristic. When disconnects are connected in series, each downstream device should use a time-current setting that will cause it to open and clear the circuit before any upstream disconnect tripping mechanism is actuated. The time-current bands of disconnects in series must not overlap and must be separated from each other sufficiently to allow for the clearing time of each disconnecting means used. The time / current selective system is recommended for applications where damage levels associated with the time / current settings used are tolerable. This type of system does not require

interlocking wiring between the GFP devices associated with main feeder and branch disconnecting devices.

Figure 16, on the next page, illustrates time / current selective coordination in a system involving a 4000 ampere main circuit breaker and a 1600 ampere feeder circuit breaker in an incoming service switchboard. These feed a distribution switchboard with a 600 ampere sub-feeder to a 100 ampere branch breaker. The system is coordinated so that only the circuit breaker nearest the location of the ground fault trips.

Zone Selective (Zone Interlock)

In this system each disconnecting means should open as quickly as possible when a ground fault occurs in the zone where this disconnect is the nearest supply source.

The GFP device for an upstream disconnecting means should have at least two modes of operation. If a ground fault occurs between it and the nearest downstream disconnect, it should operate in its fast tripping mode.

When a ground fault occurs beyond the downstream disconnect, the downstream GFP device should open in its fast tripping mode and simultaneously

send a restraining signal to the upstream device and transfer that device to a time-delay tripping mode. The upstream time-delay tripping characteristic selected should be such that the downstream disconnect will open and clear the circuit before the upstream disconnect tripping mechanism is actuated. The time-current characteristic of the upstream device should be such as to offer backup protection in the event of malfunction of the downstream equipment.

Alternatively, a restraining signal from a downstream device may be used to prevent the tripping of an upstream disconnect on ground fault instead of causing it to operate in the time-delay tripping mode. This may be done where backup protection is less important than continuity of service to critical loads supplied by the upstream unit. There are very few instances in which this is justified, and a careful study of the entire system should be made before using this type of interlocking.

For a zone selective system, the time-current bands of disconnects in series, although used only for backup protection, should not overlap and should be separate from each other sufficiently to allow for the opening time of each disconnecting means used.

Time/Current Selective Ground Coordination

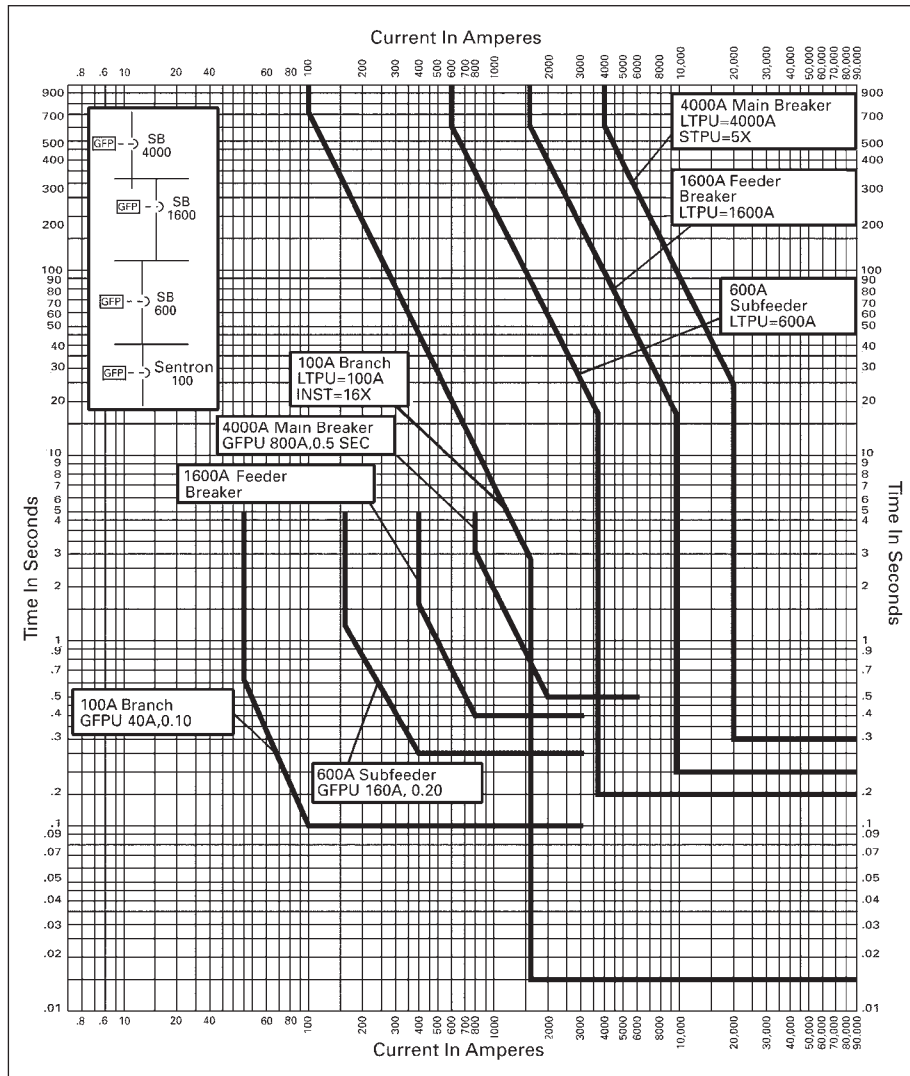

Figure 16. Fully Coordinated Multizone GFP System

The zone selective or zone interlock system provides fast tripping of the nearest disconnect upstream of the ground fault. The damage level is the lowest that is possible because the ground fault is cleared as quickly as the protective equipment can respond and the disconnect can open. Additional interlocking wiring and circuitry for sending and receiving the restraining signals are required.

The zone selective or zone interlock scheme is for those few special applications where exceptionally fast tripping is necessary for all feeders throughout the entire system to reduce damage. Note that although the relay time can be reduced appreciably, the circuit breaker mechanism and arcing time (plus safety margin) will still be present.

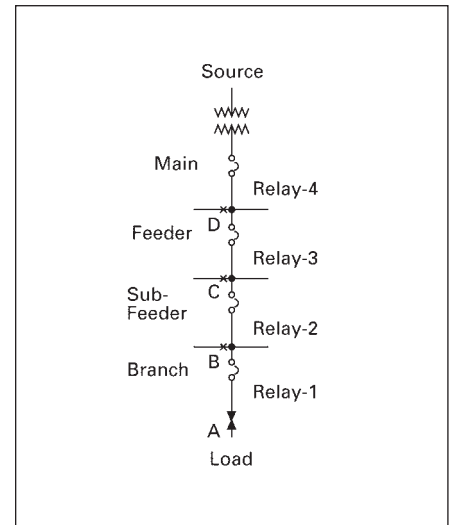

Figure 17. Zone Interlocking Scheme

Zone Selective Operation (Figure 17):

- Relay-1** will sense a ground fault at **A** when it exceeds 10 amperes. It will instantly initiate tripping of the **Branch** breaker and send restraining signals (transfer from instantaneous operation to time-delayed operation) to **Relay-2** and **Relay-3** (Relay-2 and Relay-3 will then back up Relay-1 on a time coordinated basis). **Relay-4** will be restrained by **Relay-2** if ground fault exceeds 100 amperes.
- Relay-2** will sense a ground fault at **B** when it exceeds 100 amperes. It will instantly initiate tripping of the **Sub-Feeder** breaker and send restraining signals to **Relay-3** and **Relay-4**.
- Relay-3** will sense a ground fault at **C** when it exceeds 400 amperes. It will instantly initiate tripping of the **Feeder** breaker and send a restraining signal to **Relay-4**.
- Relay-4** will sense a ground fault at **D** when it exceeds 800 amperes. It will instantly initiate tripping of the **Main** breaker.

Table 17.1

| Typical Ampere Setting | Restrained Time Delay |
|------------------------|-----------------------|
| 800 | 0.4 SEC. |
| 400 | 0.3 SEC. |
| 100 | 0.2 SEC. |
| 10 | 0.1 SEC. |

Typical Application Diagrams

Figures 18 through 23 on this and the facing page show the basic methods of applying ground fault protection (GFP). Other types of distribution systems will require variations of these methods to satisfy other system conditions.

These diagrams show circuit breakers as the disconnects. Any disconnecting

means can be utilized, providing it is suitable for use with a ground fault protection system as indicated in the scope of this application guide. The examples do not show protection against a ground fault on the supply side of the main disconnect.

Sensing device and disconnect locations define zones of protection. Source side

and ground return sensors provide protection only on the load side of associated disconnects. If a vector summation method is used and its sensors are located on load side of a disconnect, the zone between a source and actual sensor location becomes the responsibility of the next upstream protective device.

Table 17.2 Recommendations for Figures 18-23

| Ground Fault Protection | Figure | Sensing Method | Additional Ground Points | Recommended Use | Selectivity |
|---|--------|--|--|---|---|
| On Main Disconnect Only | 18 | Vector Summation | Must not be downstream. May be upstream | Minimum protection only per Section 230-95 for the National Electric Code | Limited selectivity depends on location of fault and rating of overcurrent devices on the upstream side of fault. |
| | 19 | Ground Return | None | | |
| On Main and Feeder Disconnects | 20 | Main and Feeders – Vector Summation | Must not be downstream of main ground fault sensor. May be upstream. | Improved service continuity is required | Main will allow feeder to trip for faults downstream of feeder sensors, but main will trip if feeder fails to operate. |
| | 21 | Main – Ground Return Feeders – Vector Summation | None | | |
| On Main, Feeder, and Selected Branch Disconnects with Zone Selective Interlocking | 22 | Main and feeders 1-3 – Vector Summation MCC branch feeder A – Zero Sequence | Must not be downstream of main ground fault sensor. May be upstream. | Improved service continuity and minimum arcing fault damage are required and protection is needed on branch circuits. | Main and feeder 1-3 will provide delayed backup protection if fault is downstream of MCC branch feeder A. Main will provide delayed backup protection if fault is downstream of sensors for feeders 1-3. Main will trip on fastest curve if fault is upstream of sensors for feeders 1-3. |
| Double-Ended System with Protection on Main and On Tie and Feeder Disconnects | 23 | Main and Tie – Ground Return Feeders – Vector Summation | None | Double-ended systems with ground fault protection on tie disconnect where maximum continuity of service is essential. | When operating with tie disconnect open, main will provide delayed backup protection if fault is downstream from feeder sensors. When operating with the tie disconnect closed, the tie will trip before the main, thus sectionalizing the bus. |

Ground Fault Protection on Main Disconnects Only

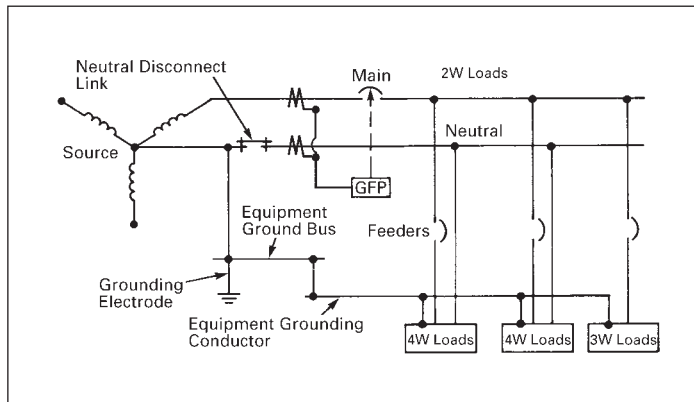

Figure 18

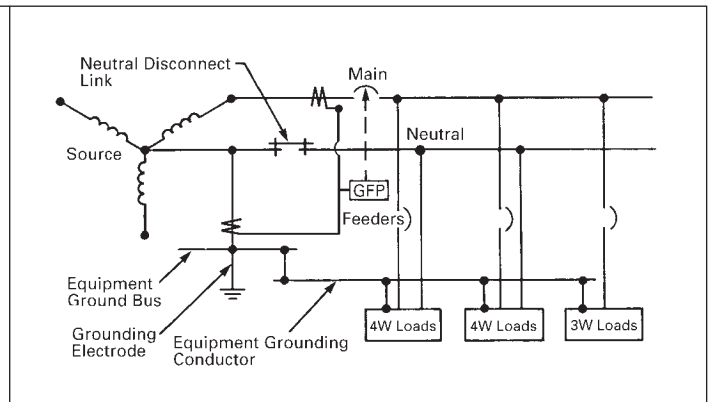

Figure 19

Ground Fault Protection on Main and Feeder Disconnects

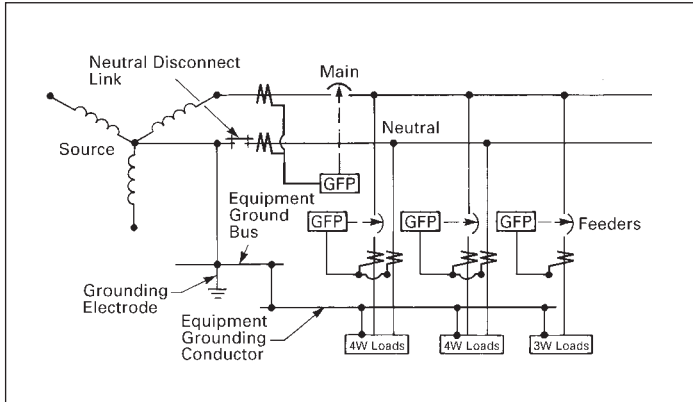

Figure 20

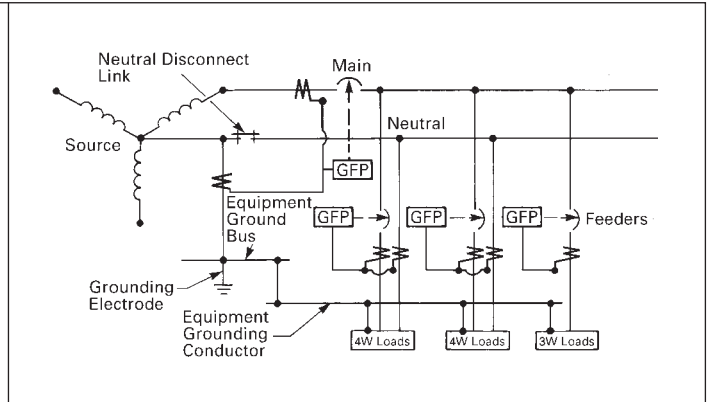

Figure 21

Ground Fault Protection on Main, Feeder and Selected Branch Disconnects with Zone Selective Interlocking

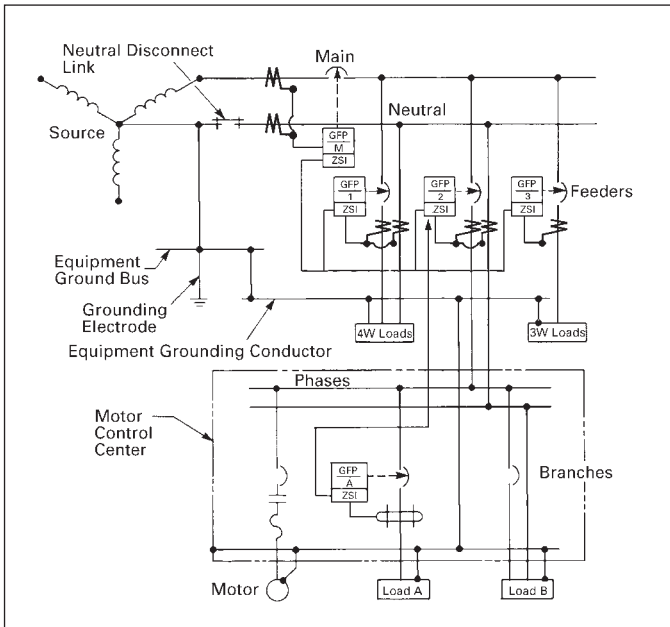

Figure 22

Double-Ended System with Ground Fault Protection on Main and on Tie and Feeder Disconnects

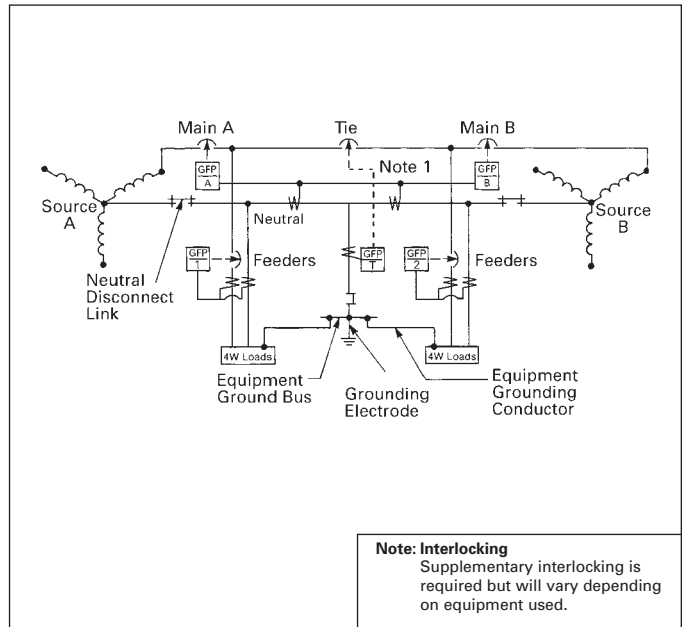

Figure 23

Coordination of a power distribution system requires that circuit protective devices be selected and set so that electrical disturbances, such as over-loads or short circuits, will be cleared promptly by isolating the faulted equipment with minimum service disruption of the distribution system. Time / Current Characteristic Curves are available for circuit protective devices, such as circuit breakers and fuses, which show how quickly they will operate at various values of overload and short circuit current. Coordination can be obtained by comparing these curves for each device in series in the system.

In developing the system, it will be noted that many compromises must be made between the various objectives:

1. System reliability.
2. Continuity of service.
3. Equipment and system protection.
4. Coordination of protective devices.
5. System cost.

Preliminary steps in Coordination study:

A) One-line diagram: used as a base on which to record pertinent data and information regarding relays, circuit breakers, fuses, current transformers, and operating equipment while at the same time, providing a convenient representation of the relationship of circuit protective devices with one another.

B) Short-circuit study: record all applicable impedances and ratings; using these values, a short-circuit study is made to determine currents available at any particular point in the system.

C) Determine maximum load currents which will exist under normal operating conditions in each of the power-system circuits, the transformer magnetizing inrush currents, and times, and the starting currents, and accelerating times of large motors. These values will determine the maximum currents which circuit protective devices must carry without operating. The upper boundary of current sensitivity will be determined by the smallest values resulting from the following considerations:

- 1) Maximum available short-circuit current obtained by calculation.
- 2) Requirements of applicable codes and standards for the protection of equipment such as cable, motors, and transformers.
- 3) Thermal and mechanical limitations of equipment.

D) Time / current characteristic curves of all the protective devices to be coordinated must be obtained. These should be

plotted on standard log-log coordination paper to facilitate the coordination study.

Mechanics Of Achieving Coordination:

The process of achieving coordination among protective devices in series is essentially one of selecting individual units to match particular circuit or equipment protection requirements, and of plotting the time/current characteristic curves of these devices on a single overlay sheet of log-log coordination paper.

The achievement of coordination is a trial-and-error routine in which the various time / current characteristic curves of the series array of devices are matched one against another on the graph plot.

When selecting protective devices one must recognize ANSI and NEC requirements and adhere to the limiting factors of coordination such as load current, short-circuit current, and motor starting. The protective devices selected must operate within these boundaries while providing selective coordination

where possible. Selective coordination is usually obtained in low voltage systems when the log-log plot of time / current characteristics displays a clear space between the characteristics of the protective devices operating in series, that is, no overlap should exist between any two time/current characteristics if full selective coordination is to be obtained. Allowance must be made for relay overtravel and for relay and fuse curve accuracy. Quite often the coordination study will stop at a point short of complete selective coordination because a compromise must be made between the competing objectives of maximum protection and maximum service continuity.

Computer Aided Coordination:

The philosophy discussed above applies to the "classical" practice of performing coordination studies manually. Today, however, there are numerous personal computer software programs available for performing coordination studies.

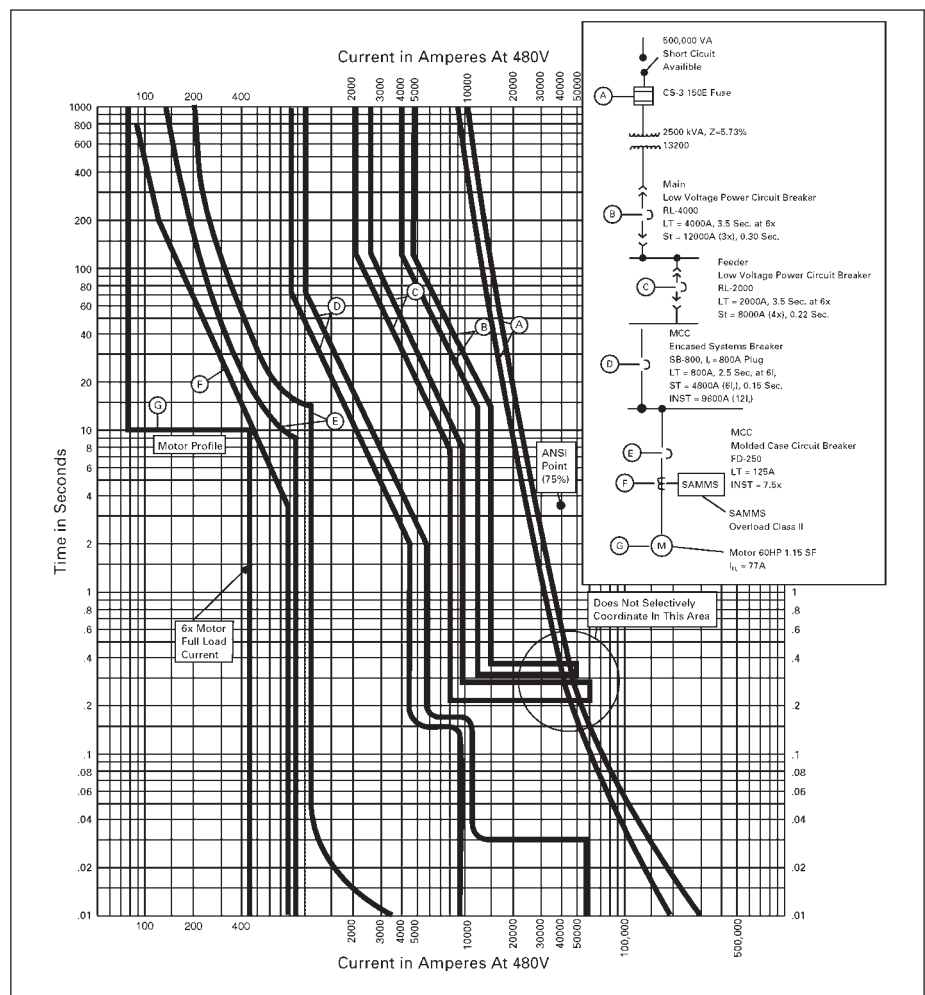

Figure 24. Coordination of Example System

General

Proper system design requires that the system be coordinated so the interrupting capacity and / or short circuit withstand capabilities of the various components in the system are not exceeded for any operating situation. Good practice also requires that the system be selective, that is, that the minimum portion of the system be interrupted on occurrence of a fault. The need for selectivity must always be balanced against the requirements of economics and coordination with the overall process needs.

At the conceptual phase of a project, several distribution system alternatives should be considered, and examined both technically and economically. This study should include sufficient detail for a thorough understanding of the system alternatives. The conceptual study should determine the optimal distribution system configuration for the project, on which definitive design can proceed.

At all stages of design, the principal objectives of personnel safety, equipment protection, process continuity, fault clearing, and service continuity should be considered.

In designing a new or modified distribution system, the following types of system studies may be needed:

- 1. Short Circuit Studies:** three phase, line-to-line, and line-to-ground faults can be calculated for both close-and-latch and interrupting conditions, necessary for checking interrupting device and related equipment ratings, and setting protective devices.
- 2. Circuit Breaker Application Studies:** consider the AC and DC decrements in the fault current, and the speed of the various medium voltage circuit breakers, to determine close-and-latch and interrupting duties.
- 3. Protective Device Coordination Studies:** determine characteristics and settings of protective devices, e.g., relays, trip devices, fuses, etc. The coordination study should provide a balance between protection of system equipment and continuity of service.

4. Load Flow Studies: calculate voltages, phase angles, real and reactive power, line and transformer loadings under simulated conditions to aid in determining the performance of a new or revamped system during the planning stage.

5. Motor Starting Studies: determine severity of voltage dips and adequacy of load accelerating torque when starting large motors on a weak system.

Today, most studies are performed using computers. Some specialized studies require large computing resources, but many studies can now be performed on personal computers. A wide variety of software packages are available. In addition, many specialty firms exist which provide engineering service to perform such studies.

Short Circuit Calculations

The single-line diagram serves as the starting point for the system study and selection of equipment ratings. The single-line must be modified to show all power sources and capacities, and system impedances. Sources of short circuit current include utility connections, local generation, and all rotating machines connected to the system at the instant the fault occurs. The system study should consider various fault types (line-to-line and line-to-ground) and fault locations.

The value of normal load current in a circuit depends on the load connected, and is essentially independent of the capacity of the power system. On the other hand, the short circuit current depends almost entirely on the capacity of the power system, not the size of the load.

The total fault current consists of a symmetrical AC component, superimposed on a DC (offset)

component. Hence, the total fault current is asymmetric with respect to the current axis. The value of the DC component depends on the point of the voltage wave at which the fault was initiated. For system studies, it is assumed that the fault is initiated at the worst point, to produce a "fully offset" fault current. This is illustrated in Figure 25.

Short circuit currents are determined by the system impedance, including both reactance and resistance. The effect of the reactance is to cause the initial fault current to be high, with the fault current declining as time proceeds. This is represented as the summation of a DC component which decays relatively rapidly over time, and an AC component, which decays at a slower rate. The rate of decay of the components depends on the system X/R ratio.

Since the reactance of rotating machines varies with the time from fault initiation, the short circuit calculations must use the appropriate machine reactance values. Subtransient reactance (X''_d) governs current flow for approximately the first 6 cycles of a fault. Then, transient reactance (X'_d) determines current flow up to around 30-120 cycles, depending on the machine. After this, synchronous reactance (X_d) applies, but studies seldom use this value as faults are not usually allowed to persist for this length of time.

For transformers, the actual tested value of the transformer impedance is used. If this is not available, use design impedance adjusted to the minimum value allowed by manufacturing tolerance of $\pm 7.5\%$. For example, a 5.75% design unit has a tolerance range of 5.32-6.18%, and 5.32% would be used in a system study prior to manufacture.

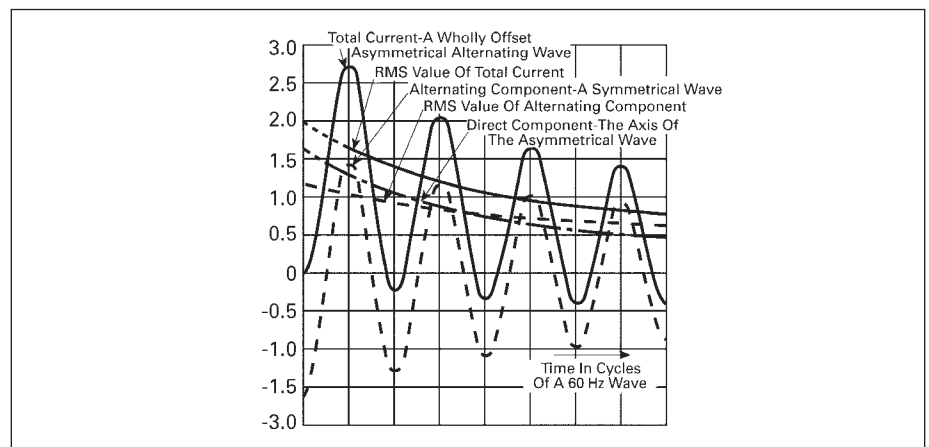

Figure 25. Structure of Asymmetrical Current Wave (Fully Offset)

Fuseless Current Limiting Circuit Breakers

The technology of Siemens Sentron® fuseless current limiting circuit breakers was developed to meet the demands of modern distribution systems. It is not uncommon for today's systems to have prospective short circuit currents approaching 200,000 amperes. Users demanded the protection and flexibility afforded by circuit breakers, without the nuisance and expense of fuse replacement.

Underwriters Laboratories, in UL489-2.4A, defines a fuseless current limiting circuit breaker as one that "does not employ a fusible element, and that when operating within its current-limiting range, limits the let-through I^2t to a value less than the I^2t of a half-cycle wave of the symmetrical prospective current."

I^2t is an expression which allows comparison of the energy available as a result of fault current flow. As used in current limiting discussions, I^2t refers to the energy released between the initiation of the fault current and the clearing of the circuit.

Figure 26 relates the "prospective I^2t " to the energy allowed by a Sentron current limiting circuit breaker, or "let-through I^2t ". The upper curve represents the maximum I^2 the circuit can produce, unaltered by the presence of any protective device. The lower curve illustrates the reduction in energy allowed when Sentron current limiting circuit breakers are used.

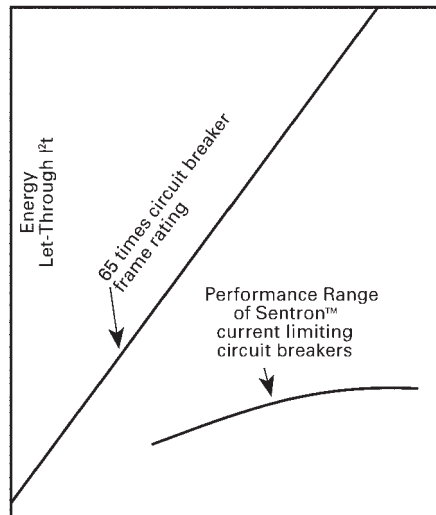

Figure 26. Reduction of I^2t Let-Through with Current-Limiting Technology

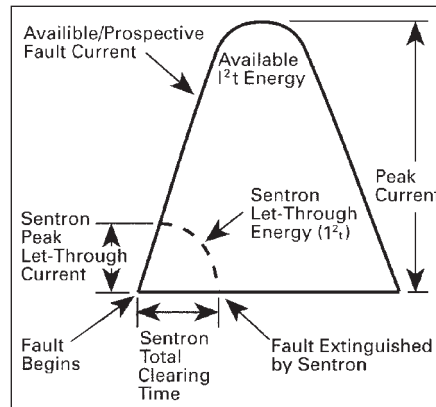

Figure 27. Current Limitation

Figure 27 illustrates how the Sentron circuit breaker limits the energy under fault conditions. The upper curve illustrates the first half-cycle wave of prospective fault current. To qualify as truly current limiting, the circuit breaker must prevent the current value from reaching the maximum value that it would reach if the circuit breaker were not connected in the circuit.

The Sentron circuit breakers use the "blow-apart" contact principle to accomplish current limitation. This principle is based on the electro-magnetic repulsion of adjacent conductors which carry current in opposite directions.

The contact arms are arranged to create opposing magnetic fields. As fault current rises, magnetic repulsion forces the contacts to separate completely. The higher the fault current, the faster this "blow-apart" action occurs.

As figure 27 illustrates, the energy let-through with the current limiting Sentron circuit breaker is decreased significantly. This provides better protection for downstream equipment, and reduces damage.

Applications and Ratings

Sentron current limiting circuit breakers are designed for use in load centers, power panelboards, distribution switchboards, secondary unit substations, and all types of individual enclosures where the available fault currents exceed the interrupting ratings of heavy duty and extra-heavy duty molded case circuit breakers.

Sentron circuit breakers have ratings of 15 through 1600 amperes, 240 through 600 volts AC, with up to 200,000 symmetrical amperes interrupting rating.

Series-Connected Rating

A series-connected rating can be assigned to a combination of components — typically circuit breakers — which has been tested in combination to a higher interrupting rating than that of the lowest rated protective device of the combination. These ratings must be substantiated by extensive UL testing.

General

Article 110.9 of the 2011 *National Electrical Code* states the following: “Equipment intended to interrupt current at fault levels shall have an interrupting rating not less than the nominal circuit voltage and the current that is available at the line terminals of the equipment. Equipment intended to interrupt current at other than fault levels shall have an interrupting rating at nominal circuit voltage not less than the current that must be interrupted.”

The difference between the phrases “at fault levels” and “at other than fault levels” is the part of the Code which makes series-connected systems possible. For example, the traditional method of satisfying the Code was to select each breaker in the series with an interrupting rating equal to or greater than the prospective fault current. The interrupting rating of a circuit breaker — stated in RMS symmetrical amperes — is the amount of short circuit current the device can safely interrupt and continue to function as a circuit breaker.

Thus, if the prospective fault current at the line terminals of a panelboard is 100,000A RMS symmetrical, this traditional method would require that all the circuit breakers within the panelboard be rated at 100,000A RMS symmetrical or greater interrupting capacity. This is illustrated in Figure 28. In the traditional system, both the main and the feeder breaker are subjected to several short circuit peaks.

In a series-connected system, however, the individual components (or circuit breakers) *have already been tested in series and the combination has been given an interrupting rating equal to or greater than various prospective fault currents which are available.* The combination, therefore, acts as a *single entity*, and performs the same protective function as individual circuit breakers in the traditional method. The difference is that combinations in series-connected systems contain devices with lower interrupting ratings.

Siemens circuit breakers used in series combinations which have passed extensive tests required by Underwriters Laboratories are listed in the *UL Recognized Component Directory* according to manufacturer’s name and type. The listing means that such circuit breakers are UL Recognized for the series interrupting ratings as noted in the Directory, and that they can be used as an entity to meet Article 110.9 of the NEC.

Using the previous example, if the prospective fault current at the line terminals of the panelboard is 100,000 amperes RMS symmetrical, the series-connected method would involve selecting a specific *combination* from the *UL Recognized Component Directory* with a rating of 100,000 amperes RMS symmetrical or greater interrupting capacity. That combination might include individual components which have lower individual interrupting ratings than 100,000 amperes RMS symmetrical.

However, all the components in the combination have been tested together and form an entity that will safely interrupt the prospective fault current of the particular situation being examined as long as the interrupting rating listed matches the prospective fault current.

With the advent of fuseless current limiting circuit breakers such as Sentron, another important development in series-connected combinations has emerged. Because of the fuseless current limiting circuit breaker’s extremely fast interrupting capability, this device provides more control over high prospective fault currents than traditional series-connected systems.

The concept behind using fuseless current limiting circuit breakers as a component in a series-connected system is twofold: (1) higher interrupting ratings, and (2) increased control over peak current (i_p) and energy let-through (I^2t).

For example, a current limiting circuit breaker is placed at the side closest to the source of power and rated according to the prospective fault current available at the line-side terminals. In effect, doing this places a “shroud of protection” over the downstream components. Because of the inherent high interrupting capability of the current limiting circuit breaker, the breaker itself meets or exceeds the prospective short circuit current. Because of its current limiting action the prospective I^2t never reaches downstream components. This is illustrated in Figure 29.

It is important to recognize that the current limiting circuit breaker be an individual component in a UL tested combination, and that it is the combination itself — current limiting circuit breaker *plus* other circuit breakers — that forms entity specified in day-to-day applications.

For specific series-connected combinations that have met UL requirements and are listed in the *UL Recognized Component Directory*, check with your local Siemens sales office listed on the back cover. Since the Directory is updated every six months, please check for additional combinations which may have been tested and approved.

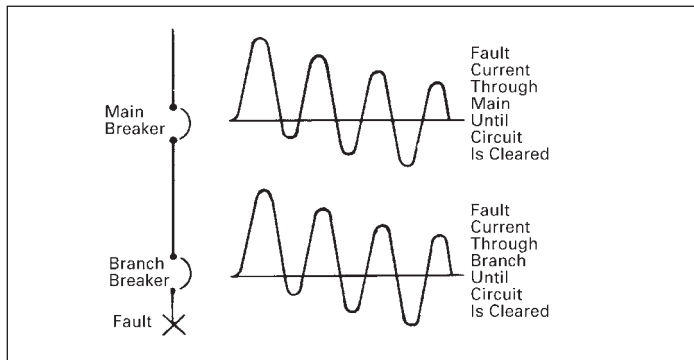

Figure 28 — Without Current Limiting

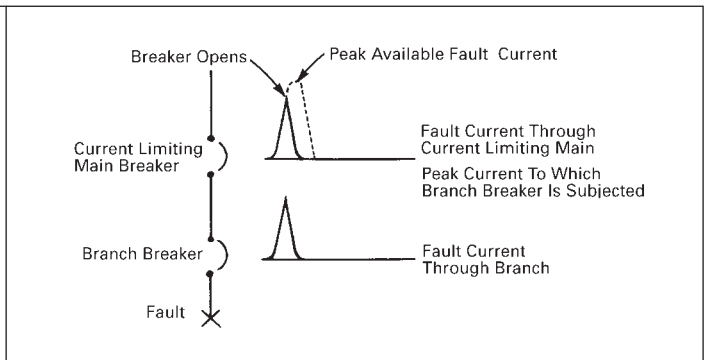

Figure 29 — Series-Connected Protective Scheme With Current Limiting Main Circuit Breaker

Non-Linear Loads

When a sinusoidal voltage is applied to a linear load, the resultant current waveform takes on the shape of a sine wave as well. Typical linear loads are resistive heating and induction motors.

In contrast, a non-linear load either:

- Draws current during only part of the cycle and acts as an open circuit for the balance of the cycle,
- or
- Changes the impedance during the cycle, hence the resultant waveform is distorted and no longer conforms to a pure sine wave shape

In recent years, the use of electronic equipment has mushroomed in both offices and industrial plants. These electronic devices are powered by switching power supplies or some type of rectifier circuit. Examples of these devices used in offices are: computers, fax machines, copiers, printers, cash registers, UPS systems, and solid-state ballasts. In industrial plants, one will find other electronic devices such as variable speed drives, HID lighting, solid-state starters and solid-state instruments. They all contribute to the distortion of the current waveform and the generation of harmonics. As the use of electronic equipment increases and it makes up a larger portion of the electrical load, many concerns are raised about its impact on the electrical power supply system.

Harmonics

As defined by ANSI / IEEE Std. 519-1992, harmonic components are represented by a periodic wave or quantity having a frequency that is an integral multiple of the fundamental frequency. Harmonics are voltages or currents at frequencies that are integer multiples of the fundamental (60 Hz) frequency: 120 Hz, 180 Hz, 240 Hz, 300 Hz, etc. Harmonics are designated by their harmonic number, or multiple of the fundamental frequency. Thus, a harmonic with a frequency of 180 Hz (three times the 60 Hz fundamental frequency) is called the 3rd harmonic.

Harmonics superimpose themselves on the fundamental waveform, distorting it and changing its magnitude. For instance, when a sine wave voltage source is applied to a non-linear load connected from a phase-leg to neutral on a 3-phase, 4-wire branch circuit, the load itself will draw a current wave made up of the 60 Hz fundamental frequency of the voltage source, plus 3rd and higher order odd harmonic (multiples of the 60 Hz fundamental frequency), which are all

Voltage of Current Waveform for Linear Loads (Sine Wave)

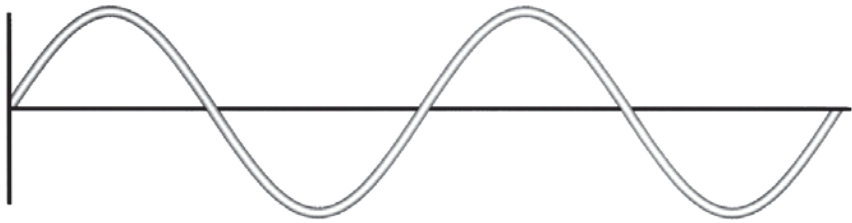

Typical Current Waveform of Switching Power Supply

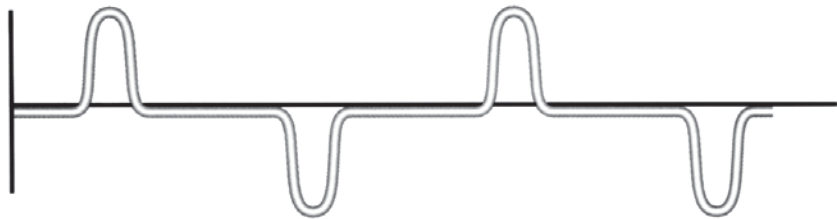

A Non-Linear Current and Its Fundamental, Plus 3rd and 5th Harmonic Components

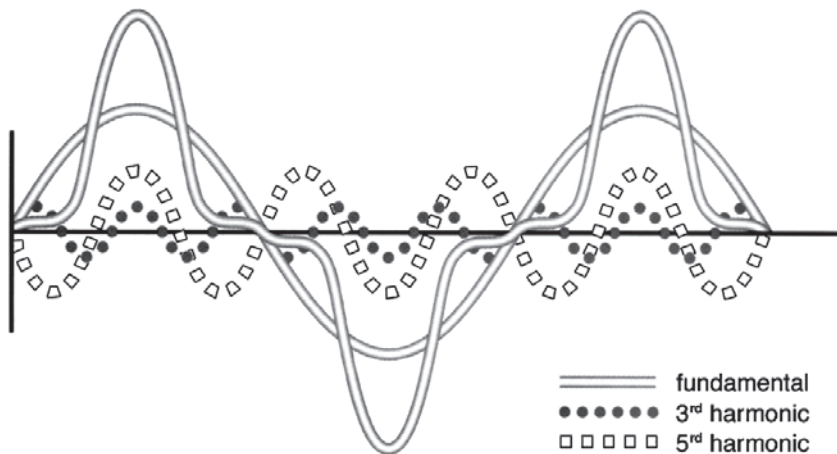

Figure 30 — Effect of Harmonics on Current Waveform

generated by the non-linear load. Total Harmonic Distortion (THD) is calculated as the square root of the sum of the squares of all harmonics divided by the normal 60 Hz value.

$$THD = \sqrt{\frac{\left(\frac{I_{RMS}}{60\text{ Hz}}\right)^2 + \left(\frac{I_{RMS}}{180\text{ Hz}}\right)^2 + \left(\frac{I_{RMS}}{N}\right)^2}{\left(\frac{I_{RMS}}{60\text{ Hz}}\right)^2}}$$

This yields an RMS value of distortion as a percentage of the fundamental 60 Hz waveform.

Therefore, it is the percentage amount of odd harmonics (3rd, 5th, 7th, ..., 25th, ...) present in the load which can affect the transformer, and this condition is called a "Non-Linear Load" or "Non-Sinusoidal Load". To determine what amount of harmonic content is present, a K-Factor calculation is made instead of using the THD formula. The total amount of harmonics will determine the percentage of non-linear load, which can be specified with the appropriate K-Factor rating.

Typical Symptoms of Harmonic Problems

- Distribution / lighting transformers overheating even when measured load current is within transformer rating
- Neutral cable / bus overheating even with balanced load
- Fuses blowing and circuit breakers tripping at currents within rating

Effect Of Harmonics On Transformers

Non-sinusoidal current generates extra losses and heating of transformer coils thus reducing efficiency and shortening the life expectancy of the transformer. Coil losses increase with the higher harmonic frequencies due to higher eddy current loss in the conductors.

Furthermore, on a balanced linear power system, the phase currents are 120 degrees out of phase and offset one another in the neutral conductor. But with the "Triplen" harmonics (multiple of 3) the phase currents are in phase and they are additive in this neutral conductor. This may cause installations with non-linear loads to double either the size or number of neutral conductors.

Table 17.5 K-Factor Ratings

| Type | Linear Load | Non-Linear Load | Total K-Factor Load Value |
|------------|-------------|-----------------|---------------------------|
| K4 | 100% | 50% | 4.0 |
| K13 | 100% | 100% | 13.0 |
| K20 | 100% | 125% | 20.0 |
| K30 | 100% | 150% | 30.0 |

Measurement of Harmonics

For existing installations, the extent of the harmonics can be measured with appropriate instruments commonly referred to as "Power Harmonic Analyzers". This service is offered by many consulting service organizations. For new construction, such information may not be obtainable. For such situations, it is best to assume the worse case condition based on experience with the type and mix of loads.

Sizing Transformers for Non-Linear Loads

ANSI / IEEE C57.110-2008 has a procedure for de-rating standard distribution transformers for non-linear loading. However this is not the only approach. A transformer with the appropriate K-Factor specifically designed for non-linear loads can be specified.

K-Factors

K-Factor is a ratio between the additional losses due to harmonics and the eddy losses at 60 Hz. It is used to specify transformers for non-linear loads. Note that K-Factor transformers do not eliminate harmonic distortion; they withstand the non-linear load condition without overheating.

Calculating K-Factor Loads

1. List the kVA value for each load category to be supplied. Next, assign a K-factor designation that corresponds to the relative level of harmonics drawn by each type of load. Refer to Table 17.7.

2. Multiply the kVA of each load or load category times the Index of Load K-rating (I_{LK}) that corresponds to the assigned K-factor rating. This result is an indexed $kVA \cdot I_{LK}$ value.
 $kVA \times I_{LK} = kVA \cdot I_{LK}$.
3. Tabulate the total connected load kVA for all load categories to be supplied.
4. Next, add-up the $kVA \cdot I_{LK}$ values for all loads or load categories to be supplied by the transformer.
5. Divide the grand total $kVA \cdot I_{LK}$ value by the total kVA load to be supplied. This will give an average I_{LK} for that combination of loads. $Total\ kVA \cdot I_{LK} / Total\ kVA = average\ I_{LK}$.
6. From Table 17.7 find the K-factor rating whose I_{LK} is equal to or greater than the calculated I_{LK} .

Table 17.7 Estimating K-Factor Loads^①

| Description | K-Factor | I_{LK} |
|--|----------|----------|
| Incandescent Lighting Electric Resistance Heating Motors (without solid state drives) Control Transformers / Electromagnetic Control Devices Motor-Generators (without solid state drives) Standard Distribution Transformers | K1 | 0.00 |
| Electric Discharge Lighting (HID) UPS with Optional Input Filter Welders Induction Heating Equipment PLCs and Solid State Controls | K4 | 25.82 |
| Telecommunications Equipment (PBX) UPS without Input Filtering Multiwire Receptacle Circuits in General Care Areas of Health Care Facilities, Schools, etc. Multiwire Receptacle Circuits Supplying Testing Equipment on an Assembly Line | K13 | 57.74 |
| Main-Frame Computer Loads Solid State Motor Drives (variable speed drives) Multiwire Receptacle Circuits in Critical Care Areas in Hospitals | K20 | 80.94 |
| Multiwire Receptacle Circuits in Industrial, Medical and Educational Laboratories Multiwire Receptacle Circuits in Commercial Office Spaces Small Main-Frames (mini and micro) | K30 | 123.54 |

^①Typical loads and K-Factor values for estimating purposes only.

Table 1

NEC Table 310.15(B)(16) (formerly Table 310.16) Allowable Ampacities of Insulated Conductors Rated Up to and Including 2000 Volts, 60°C Through 90°C (140°F Through 194°F), Not More Than Three Current-Carrying Conductors in Raceway, Cable, or Earth (Directly Buried), Based on Ambient Temperature of 30°C (86°F)^①

| Size | Copper Conductors | | | Aluminum Conductors Copper-Clad Aluminum Conductors | | | Size |
|----------------------|-------------------|-----------------|--|--|---|--|----------------------|
| | 60°C (140°F) | 75°C (167°F) | 90°C (194°F) | 60°C (140°F) | 75°C (167°F) | 90°C (194°F) | |
| AWG Kcmil | Types | Types | Types TBS SA SIS FEP FEPB RHH THHN THHW XHHW | Types | Types RHW THHW THW THWN XHHW USE | Types TBS, SA, SIS, THHN THHW THW-2, THWN-2, RHH, RHW-2 USE-2 XHH, XHHW XHHW-2, ZW-2 | AWG Kcmil |
| 18 | — | — | 14 | — | — | — | — |
| 16 | — | — | 18 | — | — | — | — |
| 14 ^② | 15 | 20 | 25 | — | — | — | — |
| 12 ^② | 20 | 25 | 30 | 15 | 20 ^② | 25 ^② | 12 |
| 10 ^② | 30 | 35 | 40 | 25 | 30 ^② | 35 ^② | 10 |
| 8 | 40 | 50 | 55 | 35 | 40 | 45 | 8 |
| 6 | 55 | 65 | 75 | 40 | 50 | 55 | 6 |
| 4 | 70 | 85 | 95 | 55 | 65 | 75 | 4 |
| 3 | 85 | 100 | 115 | 65 | 75 | 85 | 3 |
| 2 | 95 | 115 | 130 | 75 | 90 | 100 | 2 |
| 1 | 110 | 130 | 145 | 85 | 100 | 115 | 1 |
| ½ | 125 | 150 | 170 | 100 | 120 | 135 | ½ |
| ¾ | 145 | 175 | 195 | 115 | 135 | 150 | ¾ |
| 1 | 165 | 200 | 225 | 130 | 155 | 175 | 1 |
| 1½ | 195 | 230 | 260 | 150 | 180 | 205 | 1½ |
| 250 | 215 | 255 | 290 | 170 | 205 | 230 | 250 |
| 300 | 240 | 285 | 320 | 195 | 230 | 260 | 300 |
| 350 | 260 | 310 | 350 | 210 | 250 | 280 | 350 |
| 400 | 280 | 335 | 380 | 225 | 270 | 305 | 400 |
| 500 | 320 | 380 | 430 | 260 | 310 | 350 | 500 |
| 600 | 350 | 420 | 475 | 285 | 340 | 385 | 600 |
| 700 | 385 | 460 | 520 | 315 | 375 | 425 | 700 |
| 750 | 400 | 475 | 535 | 320 | 385 | 435 | 750 |
| 800 | 410 | 490 | 555 | 330 | 395 | 440 | 800 |
| 900 | 435 | 520 | 585 | 355 | 425 | 480 | 900 |
| 1000 | 455 | 545 | 615 | 375 | 445 | 500 | 1000 |
| 1250 | 495 | 590 | 665 | 405 | 485 | 545 | 1250 |
| 1500 | 525 | 625 | 705 | 435 | 520 | 585 | 1500 |
| 1750 | 545 | 650 | 735 | 455 | 545 | 615 | 1750 |
| 2000 | 555 | 665 | 750 | 470 | 560 | 630 | 2000 |

Table 2

Correction Factors for Ambient Temperature Over 30°C (86°F) Based on NEC Table 310.15(B)(2)(A)

| Ambient Temperature°C | For ambient temperature over 30°C, (86°F) multiply the ampacities shown above by the appropriate factor shown below. | | | | | | Ambient Temperature°F |
|-----------------------|--|------|------|------|------|------|-----------------------|
| 10 or less | 1.29 | 1.20 | 1.15 | 1.29 | 1.20 | 1.15 | 50 or less |
| 11-15 | 1.22 | 1.15 | 1.12 | 1.22 | 1.15 | 1.12 | 51-59 |
| 16-20 | 1.15 | 1.11 | 1.08 | 1.15 | 1.11 | 1.08 | 60-68 |
| 21-25 | 1.08 | 1.05 | 1.04 | 1.08 | 1.05 | 1.04 | 69-77 |
| 26-30 | 1.00 | 1.00 | 1.00 | 1.00 | 1.00 | 1.00 | 78-86 |
| 31-35 | .91 | .94 | .96 | .91 | .94 | .96 | 87-95 |
| 36-40 | .82 | .88 | .91 | .82 | .88 | .91 | 96-104 |
| 41-45 | .71 | .82 | .87 | .71 | .82 | .87 | 105-113 |
| 46-50 | .58 | .75 | .82 | .58 | .75 | .82 | 114-122 |
| 51-55 | .41 | .67 | .76 | .41 | .67 | .76 | 123-131 |
| 56-60 | — | .58 | .71 | — | .58 | .71 | 132-140 |
| 61-65 | — | 0.47 | 0.65 | — | 0.47 | 0.65 | 141-149 |
| 66-70 | — | 0.33 | 0.58 | — | 0.33 | 0.58 | 150-158 |
| 71-75 | — | — | 0.50 | — | — | 0.50 | 159-167 |
| 76-80 | — | — | 0.41 | — | — | 0.41 | 168-176 |
| 81-85 | — | — | 0.29 | — | — | 0.29 | 177-185 |

①Refer to 310.15(B)(2) for the ampacity correction factors where the ambient temperature is other than 30°C (86°F)

②Refer to 240.4(D) for conductor overcurrent protection limitations.

Table 4A

Motor Full-Load Currents of Three Phase AC Induction Type Motors^①

| Motor Rating Horsepower | Current in Amperes | | | |
|----------------------------|--------------------|------|------|------|
| | 208V | 230V | 460V | 575V |
| 1/4 | 1.11 | .96 | .48 | .38 |
| 1/2 | 1.34 | 1.18 | .59 | .47 |
| 3/4 | 2.4 | 2.2 | 1.1 | .9 |
| 1 | 3.5 | 3.2 | 1.6 | 1.3 |
| 1 1/2 | 4.6 | 4.2 | 2.1 | 1.7 |
| 2 | 6.6 | 6 | 3 | 2.4 |
| 3 | 7.5 | 6.8 | 3.4 | 2.7 |
| 5 | 10.6 | 9.6 | 4.8 | 3.9 |
| 7 1/2 | 16.7 | 15.2 | 7.6 | 6.1 |
| 10 | 24.2 | 22.0 | 11.0 | 9.0 |
| 15 | 30.8 | 28.0 | 14.0 | 11.0 |
| 20 | 46.2 | 42.0 | 21.0 | 17.0 |
| 25 | 59.4 | 54 | 27 | 22 |
| 30 | 74.8 | 68 | 34 | 27 |
| 40 | 88 | 80 | 40 | 32 |
| 50 | 114 | 104 | 52 | 41 |
| 60 | 143 | 130 | 65 | 52 |
| 75 | 169 | 154 | 77 | 62 |
| 100 | 211 | 192 | 96 | 77 |
| 125 | 273 | 248 | 124 | 99 |
| 150 | 343 | 312 | 156 | 125 |
| 200 | 396 | 360 | 180 | 144 |
| 250 | 528 | 480 | 240 | 192 |
| 300 | — | — | 302 | 242 |
| 350 | — | — | 361 | 289 |
| 400 | — | — | 414 | 336 |
| 450 | — | — | 477 | 382 |
| 500 | — | — | 515 | 412 |
| 575 | — | — | 590 | 472 |

Table 4B

Motor Full-Load Currents In Amperes, Single Phase, AC

| Horsepower | 115V | 230V |
|------------|------|------|
| 1/4 | 4.4 | 2.2 |
| 1/2 | 5.8 | 2.9 |
| 3/4 | 7.2 | 3.6 |
| 1 | 9.8 | 4.9 |
| 1 1/2 | 13.8 | 6.9 |
| 2 | 16 | 8 |
| 3 | 20 | 10 |
| 5 | 24 | 12 |
| 7 1/2 | 34 | 17 |
| 10 | 56 | 28 |
| 15 | 80 | 40 |
| 20 | 100 | 50 |

Table 4C

Motor Full-Load Currents In Amperes, DC

| Horsepower | 120V | 240V |
|------------|------|------|
| 1/4 | 3.1 | 1.6 |
| 1/2 | 4.1 | 2.0 |
| 3/4 | 5.4 | 2.7 |
| 1 | 7.6 | 3.8 |
| 1 1/2 | 9.5 | 4.7 |
| 2 | 13.2 | 6.6 |
| 3 | 17 | 8.5 |
| 5 | 25 | 12.2 |
| 7 1/2 | 40 | 20 |
| 10 | 58 | 29 |
| 15 | 76 | 38 |

Table 4D

Conversion Table of Polyphase Design B, C, D, and E Maximum Locked-Rotor Currents for Selection of Disconnecting Means and Controllers as Determined from Horsepower and Voltage Rating and Design Letter For use only with Sections 430-110, 440-12, 440-41, and 455-8(c) of the National Electric Code.

| Rated HP | Maximum Motor Locked-Rotor Current Amperes Two and Three Phase Design B, C, D, and E | | | | | | | | | | | |
|----------|--|-----|-----------|------|-----------|------|-----------|------|-----------|------|-----------|------|
| | 115 Volts | | 200 Volts | | 208 Volts | | 230 Volts | | 460 Volts | | 575 Volts | |
| | B, C, D | E | B, C, D | E | B, C, D | E | B, C, D | E | B, C, D | E | B, C, D | E |
| 1/4 | 40 | 40 | 23 | 23 | 22.1 | 22.1 | 20 | 20 | 10 | 10 | 8 | 8 |
| 1/2 | 50 | 50 | 28.8 | 28.8 | 27.6 | 27.6 | 25 | 25 | 12.5 | 12.5 | 10 | 10 |
| 3/4 | 60 | 60 | 34.5 | 34.5 | 33 | 33 | 30 | 30 | 15 | 15 | 12 | 12 |
| 1 | 80 | 80 | 46 | 46 | 44 | 44 | 40 | 40 | 20 | 20 | 16 | 16 |
| 2 | 100 | 100 | 57.5 | 57.5 | 55 | 55 | 50 | 50 | 25 | 25 | 20 | 20 |
| 3 | — | — | 73.6 | 84 | 71 | 81 | 64 | 73 | 32 | 36.5 | 25.6 | 29.2 |
| 5 | — | — | 105.8 | 140 | 102 | 135 | 92 | 122 | 46 | 61 | 36.8 | 48.8 |
| 7 1/2 | — | — | 146 | 210 | 140 | 202 | 127 | 183 | 63.5 | 91.5 | 50.8 | 73.2 |
| 10 | — | — | 186.3 | 259 | 179 | 249 | 162 | 225 | 81 | 113 | 64.8 | 90 |
| 15 | — | — | 267 | 388 | 257 | 373 | 232 | 337 | 116 | 169 | 93 | 135 |
| 20 | — | — | 334 | 516 | 321 | 497 | 290 | 449 | 145 | 225 | 116 | 180 |
| 25 | — | — | 420 | 646 | 404 | 621 | 365 | 562 | 183 | 281 | 146 | 225 |
| 30 | — | — | 500 | 775 | 481 | 745 | 435 | 674 | 218 | 337 | 174 | 270 |
| 40 | — | — | 667 | 948 | 641 | 911 | 580 | 824 | 290 | 412 | 232 | 330 |
| 50 | — | — | 834 | 1185 | 802 | 1139 | 725 | 1030 | 363 | 515 | 290 | 412 |
| 60 | — | — | 1001 | 1421 | 962 | 1367 | 870 | 1236 | 435 | 618 | 348 | 494 |
| 75 | — | — | 1248 | 1777 | 1200 | 1708 | 1085 | 1545 | 543 | 773 | 434 | 618 |
| 100 | — | — | 1668 | 2154 | 1603 | 2071 | 1450 | 1873 | 725 | 937 | 580 | 749 |
| 125 | — | — | 2087 | 2692 | 2007 | 2589 | 1815 | 2341 | 908 | 1171 | 726 | 936 |
| 150 | — | — | 2496 | 3230 | 2400 | 3106 | 2170 | 2809 | 1085 | 1405 | 868 | 1124 |
| 200 | — | — | 3335 | 4307 | 3207 | 4141 | 2900 | 3745 | 1450 | 1873 | 1160 | 1498 |
| 250 | — | — | — | — | — | — | — | — | 1825 | 2344 | 1460 | 1875 |
| 300 | — | — | — | — | — | — | — | — | 2200 | 2809 | 1760 | 2247 |
| 350 | — | — | — | — | — | — | — | — | 2550 | 3277 | 2040 | 2622 |
| 400 | — | — | — | — | — | — | — | — | 2900 | 3745 | 2320 | 2996 |
| 450 | — | — | — | — | — | — | — | — | 3250 | 4214 | 2600 | 3371 |
| 500 | — | — | — | — | — | — | — | — | 3625 | 4682 | 2900 | 3746 |

Table 5

Normal-Load and Fault Currents of Three Phase Transformers

| Transformer Characteristics 3-Phase | | AC Voltage 3-Phase | | | | | |
|-------------------------------------|-------------|--------------------------------|-----------------------|--------------------------------|-----------------------|--------------------------------|-----------------------|
| | | 208V | | 240V | | 480V | |
| kVA Rating | % Impedance | Normal Load Continuous Amperes | Short Circuit Current | Normal Load Continuous Amperes | Short Circuit Current | Normal Load Continuous Amperes | Short Circuit Current |
| 112.5 | 3.90 | 312 | 8,007 | 271 | 6,940 | 135 | 3,470 |
| 150 | 3.70 | 416 | 11,253 | 361 | 9,753 | 180 | 4,876 |
| 225 | 4.70 | 625 | 13,288 | 541 | 11,517 | 271 | 5,758 |
| 300 | 4.50 | 834 | 18,505 | 722 | 16,038 | 361 | 8,019 |
| 500 | 4.50 | 1388 | 30,842 | 1203 | 26,730 | 601 | 13,365 |
| 750 | 5.75 | 2080 | 36,206 | 1804 | 31,379 | 902 | 15,689 |
| 1000 | 5.75 | 2780 | 48,275 | 2406 | 41,838 | 1203 | 20,919 |
| 1500 | 5.75 | 4162 | 72,412 | 3610 | 62,575 | 1805 | 31,379 |
| 2000 | 5.75 | — | — | 4812 | 83,676 | 2406 | 41,838 |
| 2500 | 5.75 | — | — | 6010 | 104,596 | 3008 | 52,298 |

① Values may vary depending on manufacturer, type of motor and NEMA design. For full load currents of 200 volt motors, increase the corresponding 230 volt motor full-load current by 15 percent.

Table 5 Notes:

1. Primary source available is assumed as 500 MVA at the primary of the transformer with a source circuit X/R ratio of 12.
2. Motor contribution is included in the table at twice the full-load current for 208 volt transformers and at 4 times the full-load current for 240 volt and 480 volt transformers. These values are derived from the assumption that 208 volt systems are 50% motor load and 240 and 480 volt systems are 100% motor load.
3. All short circuit current values are in symmetrical RMS amperes.

Table 6

Electrical Formulas for Finding Amperes, Horsepower, Kilowatts and kVA

| To Find | Single Phase | Alternating Current Two Phase [ⓐ] , Four Wire | Three Phase | Direct Current |
|----------------------------------|---|--|---|---|
| Kilowatts | $\frac{I \times E \times pf}{1000}$ | $\frac{I \times E \times 2 \times pf}{1000}$ | $\frac{I \times E \times 1.73 \times pf}{1000}$ | $\frac{I \times E}{1000}$ |
| kVA | $\frac{I \times E}{1000}$ | $\frac{I \times E \times 2}{1000}$ | $\frac{I \times E \times 1.73}{1000}$ | — |
| Horsepower (Output) | $\frac{I \times E \times \% \text{ EFF} \times pf}{746}$ | $\frac{I \times E \times 2 \times \% \text{ EFF} \times pf}{746}$ | $\frac{I \times E \times 1.73 \times \% \text{ EFF} \times pf}{746}$ | $\frac{I \times E \times \% \text{ EFF}}{746}$ |
| Amperes when Horsepower is Known | $\frac{HP \times 746}{E \times \% \text{ EFF} \times pf}$ | $\frac{HP \times 746}{2 \times E \times \% \text{ EFF} \times pf}$ | $\frac{HP \times 746}{1.73 \times E \times \% \text{ EFF} \times pf}$ | $\frac{HP \times 746}{E \times \% \text{ EFF}}$ |
| Amperes when Kilowatts is Known | $\frac{KW \times 1000}{E \times pf}$ | $\frac{KW \times 1000}{2 \times E \times pf}$ | $\frac{KW \times 1000}{1.73 \times E \times pf}$ | $\frac{KW \times 1000}{E}$ |
| Amperes when kVA is Known | $\frac{kVA \times 1000}{E}$ | $\frac{kVA \times 1000}{2 \times E}$ | $\frac{kVA \times 1000}{1.73 \times E}$ | — |

Average Efficiency and Power Factor Values of Motors

When the actual efficiencies and power factors of the motors to be controlled are not known, the following approximations may be used.

Efficiencies:

- DC motors, 35 horsepower and less 80% to 85%
- DC motors, above 35 horsepower 85% to 90%
- Synchronous motors (at 100% power factor) 92% to 95%

“Apparent” Efficiencies

(= Efficiency x Power Factor);

- Three phase induction motors, 25 horsepower and less 70%
- Three phase induction motors above 25 horsepower 80%

These figures may be decreased slightly for single phase and two phase induction motors.

Fault-Current Calculation on Low-Voltage AC Systems

In order to determine the maximum interrupting rate of the circuit breakers in a distribution system it is necessary to calculate the current which could flow under a three phase bolted short circuit condition. For a three phase system the maximum available fault current at the secondary side of the transformer can be obtained by use of the formula:

$$I_{sc} = \frac{kVA \times 100}{KV \times \sqrt{3} \times \% Z}$$

where:

I_{sc} = Symmetrical RMS amperes of fault current.

kVA = Kilovolt-ampere rating of transformers.

KV = Secondary voltage in kilovolts.

% Z = Percent impedance of primary line and transformer.

Table 5 on page T-18 has been prepared to list the symmetrical RMS fault current which is available at the secondary terminals of the transformer.

Table 8[ⓐ]

Minimum Size Grounding Conductors for Grounding Raceways and Equipment (From NEC Table 250–122)

| Rating or Setting of Automatic Overcurrent Device in Circuit Ahead of Equipment, Conduit etc., Not Exceeding (Amperes) | Size | |
|--|--------------------|--|
| | Copper Wire Number | Aluminum or Copper Clad Aluminum Wire Number |
| 15 | 14 | 12 |
| 20 | 12 | 10 |
| 30 | 10 | 8 |
| 40 | 10 | 8 |
| 60 | 10 | 8 |
| 100 | 8 | 6 |
| 200 | 6 | 4 |
| 300 | 4 | 2 |
| 400 | 3 | 1 |
| 500 | 2 | 1/0 |
| 600 | 1 | 2/0 |
| 800 | 1/0 | 3/0 |
| 1000 | 2/0 | 4/0 |
| 1200 | 3/0 | 250 kcmil |
| 1600 | 4/0 | 350 kcmil |
| 2000 | 250 kcmil | 400 kcmil |
| 2500 | 350 kcmil | 600 kcmil |
| 3000 | 400 kcmil | 600 kcmil |
| 4000 | 500 kcmil | 750 kcmil |
| 5000 | 700 kcmil | 1200 kcmil |
| 6000 | 800 kcmil | 1200 kcmil |

Note: Where necessary to comply with 250.4(A)(5) or (B) (4), the equipment grounding conductor shall be sized larger than given in this table.

Table 7[ⓐ]

Grounding Electrode Conductor for AC Systems (From NEC Table 250–66)

| Size of Largest Service Entrance Conductor or Equivalent Area for Parallel Conductors | | Size of Grounding Electrode Conductor | |
|---|----------------------------------|---------------------------------------|----------------------------------|
| Copper | Aluminum or Copper Clad Aluminum | Copper | Aluminum or Copper Clad Aluminum |
| 2 or smaller | 1/0 or smaller | 8 | 6 |
| 1 or 1/0 | 2/0 or 3/0 | 6 | 4 |
| 2/0 or 3/0 | 4/0 or 250 kcmil | 4 | 2 |
| Over 3/0 to 350 kcmil | Over 250 kcmil to 500 kcmil | 2 | 1/0 |
| Over 350 kcmil to 600 kcmil | Over 500 kcmil to 900 kcmil | 1/0 | 3/0 |
| Over 600 kcmil to 1100 kcmil | Over 900 kcmil to 1750 kcmil | 2/0 | 4/0 |
| Over 1100 kcmil | Over 1750 kcmil | 3/0 | 250 kcmil |

ⓐIn three wire, two phase circuits the current in the common conductor is 1.41 times that in either other conductor.

ⓐAdditional information and exceptions are stated in Article 250 — Grounding, National Electrical Code.

E = Volts I = Amperes
% EFF = Per Cent Efficiency pf = Power Factor

Molded Case Circuit Breakers

Article 460.8 (NEC)

The ampacity of capacitor circuit conductors shall not be less than 135% of the rated current of the capacitor. The ampacity of conductors that connect a capacitor to the terminals of a motor or to motor circuit conductors shall not be less than one-third the ampacity of the motor circuit conductors and in no case less than 135% of the rated current of the capacitor.

Application

Circuit breakers and switches for use with capacitors must have a current rating in excess of rated capacitor current to provide for overcurrent from overvoltages at fundamental frequency and harmonic currents. Use the following percent of capacitor current rating to size circuit breaker or fused and non-fused switches.

- **Enclosed Circuit Breakers** 150%
(Includes derating factor for enclosure)
- **Fused and non-fused switches** 165%

Due to switching surges, and possible overcurrent related to overvoltage and harmonics, Siemens recommends using 150% of the capacitor current rating to size a thermal-magnetic circuit breaker for overload protection.

If the circuit breaker is to be applied in an ambient greater than the marked rated ambient, it may be necessary to derate the continuous current rating. This is also true for applications where harmonic components are present. A basic formula to use for calculation of the capacitor current rating is as follows (assuming three phase application):

$$\frac{\text{Capacitor (Kvar)} \times 1000}{(\text{Voltage} / 1.732) \times 3}$$

The interrupting rating of the circuit breaker or fuse must be selected to match the system fault current available at the point of the capacitor application.

Table 17.37 Capacitor Application

| Capacitor Rating | | Amperage | | | Capacitor Rating | | Amperage | | | |
|------------------|------------------|------------------|-----------------------------|------------------|------------------|------------------|------------------|-----------------------------|------------------|----|
| Voltage | K _{var} | Capacitor Rating | Enclosed Switch Fuse Rating | MCCB Trip Rating | Voltage | K _{var} | Capacitor Rating | Enclosed Switch Fuse Rating | MCCB Trip Rating | |
| 240 | 2.5 | 6 | 15 | 15 | 480 (cont'd) | 125 | 150 | 250 | 225 | |
| | 5 | 12 | 20 | 20 | | 150 | 180 | 300 | 300 | |
| | 7.5 | 18 | 30 | 30 | | 160 | 192 | 350 | 300 | |
| | 10 | 24.1 | 40 | 40 | | 180 | 216 | 400 | 350 | |
| | 15 | 36.1 | 60 | 60 | | 200 | 241 | 400 | 400 | |
| | 20 | 48.1 | 80 | 80 | | 225 | 271 | 500 | 500 | |
| | 25 | 60 | 100 | 90 | | 240 | 289 | 500 | 500 | |
| | 30 | 72.2 | 125 | 125 | | 250 | 301 | 500 | 500 | |
| | 45 | 108 | 200 | 175 | | 300 | 361 | 600 | 600 | |
| | 50 | 120 | 200 | 200 | | 320 | 385 | 700 | 600 | |
| | 60 | 144 | 250 | 225 | | 360 | 433 | 800 | 700 | |
| | 75 | 180 | 300 | 275 | | 375 | 451 | 800 | 700 | |
| | 90 | 217 | 400 | 350 | | 400 | 481 | 800 | 800 | |
| | 100 | 240 | 400 | 400 | | 450 | 541 | 900 | 900 | |
| | 120 | 289 | 500 | 450 | | 600 | 5 | 4.8 | 15 | 15 |
| | 125 | 301 | 500 | 450 | | | 7.5 | 7.2 | 15 | 15 |
| | 135 | 325 | 600 | 500 | | | 10 | 9.6 | 20 | 15 |
| 150 | 361 | 600 | 500 | 15 | 14.4 | | 25 | 30 | | |
| 180 | 433 | 800 | 700 | 20 | 19.2 | | 35 | 30 | | |
| 200 | 480 | 800 | 800 | 25 | 24.1 | | 40 | 40 | | |
| 225 | 541 | 900 | 900 | 30 | 28.9 | | 50 | 50 | | |
| 240 | 578 | 1000 | 900 | 35 | 33.7 | | 60 | 50 | | |
| 250 | 602 | 1000 | 900 | 40 | 38.5 | | 70 | 70 | | |
| 270 | 650 | 1200 | 1000 | 45 | 43.3 | | 80 | 70 | | |
| 300 | 720 | 1200 | 1200 | 50 | 48.1 | | 80 | 100 | | |
| 360 | 866 | 1600 | 1400 | 60 | 57.7 | | 100 | 100 | | |
| 375 | 903 | 1600 | 1400 | 75 | 72.2 | | 125 | 125 | | |
| 480 | 2 | 2.41 | 15 | 15 | 80 | | 77 | 150 | 125 | |
| | 5 | 6 | 15 | 15 | 100 | | 96.2 | 175 | 150 | |
| | 7.5 | 9 | 15 | 15 | 120 | | 115 | 200 | 175 | |
| | 10 | 12 | 20 | 20 | 125 | | 120 | 200 | 200 | |
| | 15 | 18 | 30 | 30 | 150 | 144 | 250 | 225 | | |
| | 20 | 24 | 40 | 40 | 160 | 154 | 300 | 250 | | |
| | 25 | 30 | 50 | 50 | 180 | 173 | 300 | 300 | | |
| | 30 | 36.1 | 60 | 50 | 200 | 192 | 300 | 300 | | |
| | 35 | 42.1 | 70 | 60 | 225 | 217 | 400 | 350 | | |
| | 40 | 48.1 | 80 | 70 | 240 | 231 | 400 | 350 | | |
| | 45 | 54.1 | 90 | 80 | 250 | 241 | 400 | 400 | | |
| | 50 | 60.1 | 100 | 100 | 300 | 289 | 500 | 450 | | |
| | 60 | 72.2 | 125 | 110 | 320 | 308 | 600 | 500 | | |
| | 75 | 90.2 | 150 | 150 | 360 | 346 | 600 | 600 | | |
| | 80 | 96.2 | 175 | 150 | 375 | 361 | 600 | 600 | | |
| | 90 | 108.3 | 200 | 175 | 400 | 385 | 700 | 600 | | |
| | 100 | 120.3 | 200 | 200 | 450 | 433 | 800 | 700 | | |
| 120 | 144 | 250 | 225 | | | | | | | |

Fractions to Decimals to Millimeters

| Fractions | Decimals | Millimeters |
|-----------|----------|-------------|
| 1/64 | 0.015625 | 0.397 |
| 1/32 | 0.03125 | 0.794 |
| 3/64 | 0.046875 | 1.191 |
| 1/16 | 0.0625 | 1.588 |
| 5/64 | 0.078125 | 1.984 |
| 3/32 | 0.09375 | 2.381 |
| 7/64 | 0.109375 | 2.778 |
| 1/8 | 0.1250 | 3.175 |
| 9/64 | 0.140625 | 3.572 |
| 5/32 | 0.15625 | 3.969 |
| 11/64 | 0.171875 | 4.366 |
| 3/16 | 0.1875 | 4.763 |
| 13/64 | 0.203125 | 5.159 |
| 7/32 | 0.21875 | 5.556 |
| 15/64 | 0.234375 | 5.953 |
| 1/4 | 0.2500 | 6.350 |
| 17/64 | 0.265625 | 6.747 |
| 9/32 | 0.28125 | 7.144 |
| 19/64 | 0.296875 | 7.541 |
| 5/16 | 0.3125 | 7.938 |
| 21/64 | 0.328125 | 8.334 |
| 11/32 | 0.34375 | 8.731 |
| 23/64 | 0.359375 | 9.128 |
| 3/8 | 0.3750 | 9.525 |
| 25/64 | 0.390625 | 9.922 |
| 13/32 | 0.40625 | 10.319 |
| 27/64 | 0.421875 | 10.716 |
| 7/16 | 0.4375 | 11.113 |
| 29/64 | 0.453125 | 11.509 |
| 15/32 | 0.46875 | 11.906 |
| 31/64 | 0.484375 | 12.303 |
| 1/2 | 0.500 | 12.700 |
| 33/64 | 0.515625 | 13.097 |
| 17/32 | 0.53125 | 13.494 |
| 35/64 | 0.546875 | 13.891 |
| 9/16 | 0.5625 | 14.288 |
| 37/64 | 0.578125 | 14.684 |
| 19/32 | 0.59375 | 15.081 |
| 39/64 | 0.609375 | 15.478 |
| 5/8 | 0.6250 | 15.875 |
| 41/64 | 0.640625 | 16.272 |
| 21/32 | 0.65625 | 16.669 |
| 43/64 | 0.671875 | 17.066 |
| 11/16 | 0.6875 | 17.463 |
| 45/64 | 0.703125 | 17.859 |
| 23/32 | 0.71875 | 18.256 |
| 47/64 | 0.734375 | 18.653 |
| 3/4 | 0.7500 | 19.050 |
| 49/64 | 0.765625 | 19.447 |
| 25/32 | 0.78125 | 19.844 |
| 51/64 | 0.796875 | 20.241 |
| 13/16 | 0.8125 | 20.638 |
| 53/64 | 0.828125 | 21.034 |
| 27/32 | 0.84375 | 21.431 |
| 55/64 | 0.859375 | 21.828 |
| 7/8 | 0.8750 | 22.225 |
| 57/64 | 0.890625 | 22.622 |
| 29/32 | 0.90625 | 23.019 |
| 59/64 | 0.921875 | 23.416 |
| 15/16 | 0.9375 | 23.813 |
| 61/64 | 0.953125 | 24.209 |
| 31/32 | 0.96875 | 24.606 |
| 63/64 | 0.984375 | 25.003 |
| 1 | 1.000 | 25.400 |

Millimeters to Inches^①

| Millimeters | Inches | Millimeters | Inches |
|-------------|--------|-------------|--------|
| 0.1 | 0.0039 | 46 | 1.8110 |
| 0.2 | 0.0079 | 47 | 1.8504 |
| 0.3 | 0.0118 | 48 | 1.8898 |
| 0.4 | 0.0157 | 49 | 1.9291 |
| 0.5 | 0.0197 | 50 | 1.9685 |
| 0.6 | 0.0236 | 51 | 2.0079 |
| 0.7 | 0.0276 | 52 | 2.0472 |
| 0.8 | 0.0315 | 53 | 2.0866 |
| 0.9 | 0.0354 | 54 | 2.1260 |
| | | 55 | 2.1654 |
| 1 | 0.0394 | 56 | 2.2047 |
| 2 | 0.0787 | 57 | 2.2441 |
| 3 | 0.1181 | 58 | 2.2835 |
| 4 | 0.1575 | 59 | 2.3228 |
| 5 | 0.1969 | 60 | 2.3622 |
| 6 | 0.2362 | 61 | 2.4016 |
| 7 | 0.2756 | 62 | 2.4409 |
| 8 | 0.3150 | 63 | 2.4803 |
| 9 | 0.3543 | 64 | 2.5197 |
| 10 | 0.3937 | 65 | 2.5591 |
| 11 | 0.4331 | 66 | 2.5984 |
| 12 | 0.4724 | 67 | 2.6378 |
| 13 | 0.5118 | 68 | 2.6772 |
| 14 | 0.5512 | 69 | 2.7165 |
| 15 | 0.5906 | 70 | 2.7559 |
| 16 | 0.6299 | 71 | 2.7953 |
| 17 | 0.6693 | 72 | 2.8346 |
| 18 | 0.7087 | 73 | 2.8740 |
| 19 | 0.7480 | 74 | 2.9134 |
| 20 | 0.7874 | 75 | 2.9528 |
| 21 | 0.8268 | 76 | 2.9921 |
| 22 | 0.8661 | 77 | 3.0315 |
| 23 | 0.9055 | 78 | 3.0709 |
| 24 | 0.9449 | 79 | 3.1102 |
| 25 | 0.9843 | 80 | 3.1496 |
| 26 | 1.0236 | 81 | 3.1890 |
| 27 | 1.0630 | 82 | 3.2283 |
| 28 | 1.1024 | 83 | 3.2677 |
| 29 | 1.1417 | 84 | 3.3071 |
| 30 | 1.1811 | 85 | 3.3465 |
| 31 | 1.2205 | 86 | 3.3858 |
| 32 | 1.2598 | 87 | 3.4252 |
| 33 | 1.2992 | 88 | 3.4646 |
| 34 | 1.3386 | 89 | 3.5039 |
| 35 | 1.3780 | 90 | 3.5433 |
| 36 | 1.4173 | 91 | 3.5827 |
| 37 | 1.4567 | 92 | 3.6220 |
| 38 | 1.4961 | 93 | 3.6614 |
| 39 | 1.5354 | 94 | 3.7008 |
| 40 | 1.5748 | 95 | 3.7402 |
| 41 | 1.6142 | 96 | 3.7795 |
| 42 | 1.6535 | 97 | 3.8189 |
| 43 | 1.6929 | 98 | 3.8583 |
| 44 | 1.7323 | 99 | 3.8976 |
| 45 | 1.7717 | 100 | 3.9370 |

①0.001" = 0.0254 mm
1 mm = 0.03937"

